User Manual

Lithium Battery Pack

Soluna EOS-5K Pack

SOLUNA (Shanghai) Co.,Ltd.

Feb.2021 | Revision A.1

About this manual

This manual describes how to install the Soluna EOS-5K Pack. Read this manual before you attempt to install the product, and follow the instructions throughout the installation process. If you are uncertain about any of the requirements, recommendations, or safety procedures described in this manual, contact Soluna immediately for advice and clarification. The information included in this manual is accurate at the time of publication. However, with regards to the product design and technical specification updates, our company reserves the right to make changes at any time without prior notice. In addition, the illustrations in this manual are meant to help explain system configuration concepts and installation instructions. The illustrated items may differ from the actual items at the installation location.











Content

1 Safety precautions	4
1.1 Warning Signs.....	4
1.2 Safety instructions.....	4
1.2.1 Risks of explosion.....	5
1.2.2 Risks of fire.....	5
1.2.3 Risks of electric shock.....	5
1.2.4 Risks of damage to the battery pack.....	5
1.3 Battery handling guide.....	5
1.4 Response to emergency situations.....	6
1.4.1 Leaking batteries.....	6
1.4.2 Inhalation.....	6
1.4.3 Eye contact.....	6
1.4.4 Skin contact.....	6
1.4.5 Ingestion.....	6
1.4.6 Fire.....	6
1.4.7 Wet batteries.....	7
1.4.8 Damaged batteries.....	7
1.5 Qualified installers.....	7
2 Product Introduction	8
2.1 Features.....	8
2.2 Application.....	8
2.3 Outline Dimensions.....	9
2.4 Technical data.....	10
2.5 Appearance.....	12
2.6 Wring port.....	13
2.7 CAN communication interface definition (CAN1&CAN2).....	14
2.8 LED lights definition.....	15
3 Installation	16
3.1 Unpacking the package.....	16
3.2 Packing lists.....	18
3.3 Installation materials.....	18
3.4 Installation location.....	18
3.5 Installation tools.....	19
3.6 Safety gear.....	20
3.7 Wiring specification.....	20
3.8 CAN communication wiring.....	21
3.8.1. Single battery unit.....	21
3.8.2 The battery units are connected in parallel.....	22
4.How to operate Soluna EOS-5K Pack	23
5. Electrical connection	24
6 Troubleshooting	25
7 Contact us	26

1 Safety precautions

1.1 Warning Signs

Warning signs are used to warn you about the conditions that may cause severe injury or damage to the device. They instruct you to exercise caution to prevent danger. The following table describes the warning signs used in this manual.

Sign	Description
	This battery pack contains high voltage which can cause electric shock resulting in severe injury.
	Make sure that the battery polarity is connected correctly.
	Keep the battery pack away from open flame or ignition sources
	Keep the battery pack away from children.
	Read the manual before installing and operating the battery pack.
	The battery pack is heavy enough to cause severe injury
	The battery pack may leak corrosive electrolyte.
	The battery pack may explode.
	The battery pack should not be disposed with household waste at the end of its working life.
	Physical injury or damage to the devices may occur if related requirements are not followed

1.2 Safety instructions

For safety reasons, installers are responsible for familiarizing themselves with the contents of this manual and all warnings before performing installation.

General safety precautions



Failure to observe the precautions described in this section can cause serious injury to persons or damage to property, observe the following precautions

1.2.1 Risks of explosion

- Do not subject the battery pack to strong impacts.
- Do not crush or puncture the battery pack.
- Do not dispose of the battery pack in a fire.

1.2.2 Risks of fire

- Do not expose the battery pack to temperatures in excess of 60°C.
- Do not place the battery pack near a heat source, such as a fireplace.
- Do not expose the battery pack to direct sunlight.
- Do not allow the battery connectors to touch conductive objects such as wires.

1.2.3 Risks of electric shock

- Do not disassemble the battery pack.
- Do not touch the battery pack with wet hands.
- Do not expose the battery pack to moisture or liquids.
- Keep the battery pack away from children and animals.

1.2.4 Risks of damage to the battery pack

- Do not allow the battery pack to come in contact with liquids.
- Do not subject the battery pack to high pressures.
- Do not place any objects on top of the battery pack.

1.3 Battery handling guide

- Use the battery pack only as directed.
- Do not use the battery pack if it is defective, appears cracked, broken or otherwise damaged, or fails to operate broken or otherwise damaged, or fails to operate.
- Do not attempt to open, disassemble, repair, tamper with, or modify the battery pack. The battery pack is not user serviceable.
- To protect the battery pack and its components from damage when transporting, handle with care.
- Do not impact, pull, drag or step on the battery pack.
- Do not subject it to any strong force.

-
- Do not insert foreign objects into any part of the battery pack.
 - Do not use cleaning solvents to clean the battery pack.

1.4 Response to emergency situations

The Soluna EOS-5K Pack battery pack comprises multiple batteries that are designed to prevent hazards resulting from failures. However, SOLUNA cannot guarantee their absolute safety.

1.4.1 Leaking batteries

If the battery pack leaks electrolyte, avoid contact with the leaking liquid or gas. Electrolyte is corrosive and contact may cause skin irritation and chemical burns. If one is exposed to the leaked substance, do these actions:

1.4.2 Inhalation

Evacuate the contaminated area, and seek medical attention immediately.

1.4.3 Eye contact

Rinse eyes with flowing water for 15 minutes, and seek medical attention immediately.

1.4.4 Skin contact

Wash the affected area thoroughly with soap and water, and seek medical attention immediately.

1.4.5 Ingestion

Induce vomiting, and seek medical attention immediately.

1.4.6 Fire

In case there is a fire, always have an ABC or carbon dioxide extinguisher.



The battery pack may catch fire when heated above 150°C.
If a fire breaks out where the battery pack is installed, do these actions:

- Extinguish the fire before the battery pack catches fire.
- If it is impossible to extinguish the fire but you have time, move the battery pack to a safe area before it catches fire.
- If the battery pack has caught fire, do not try to extinguish the fire. Evacuate people immediately.



If the battery catches fire, it will produce noxious and poisonous gases. Do not approach.

1.4.7 Wet batteries

If the battery pack is wet or submerged in water, do not try to access it. Contact SOLUNA or your distributor for technical assistance.

1.4.8 Damaged batteries

Damaged batteries are dangerous and must be handled with extreme caution. They are not fit for use and may pose a danger to people or property.

If the battery pack seems to be damaged, pack it in its original container, and then return it to SOLUNA or your distributor.



Damaged batteries may leak electrolyte or produce flammable gas. If you suspect such damage, immediately contact SOLUNA for advice and information.

1.5 Qualified installers

This manual and the tasks and procedures described herein are intended for use by skilled workers only. A skilled worker is defined as a trained and qualified electrician or installer who has all of the following skills and experience:

- Knowledge of the functional principles and operation of on-grid systems.
- Knowledge of the dangers and risks associated with installing and using electrical devices and acceptable mitigation methods.
- Knowledge of the installation of electrical devices
- Knowledge of and adherence to this manual and all safety precautions and best practices.

2 Product Introduction

Soluna EOS-5K Pack is an LiFePO₄ lithium battery product with BMS (battery management system). It is a battery module with CAN communication, under-voltage, over-voltage, over-current, over-temperature, under-temperature protection functions. It has the characteristics of high energy density, long life, safety and reliability and so on, and It is your trustworthy green environmental product.

2.1 Features

- Excellent safety performance.
- Long cycle life.
- Support for CAN-communication.
- Parallel interconnection of several systems.
- Number of expandable battery units.

2.2 Application

- Back-up power
- Micro-grid
- Home Energy Storage system

2.3 Outline Dimensions

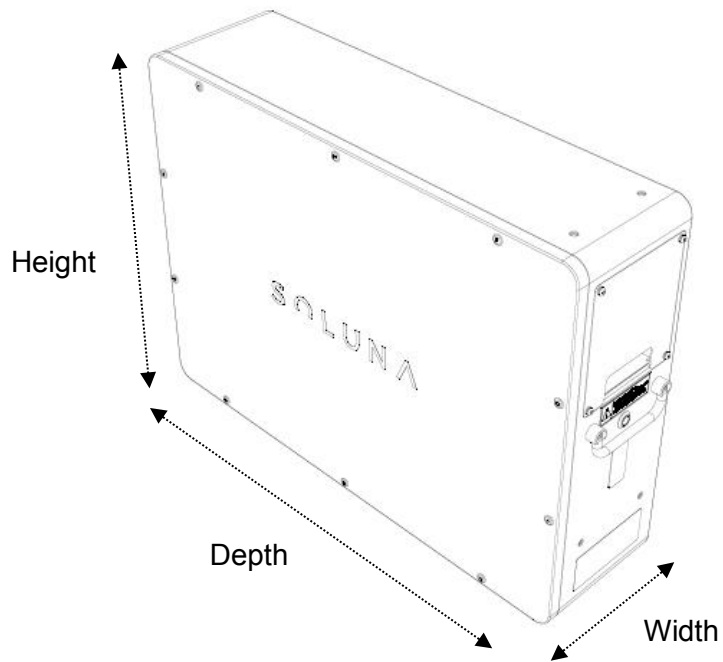

Figure 2.1 outline dimension

Width	165	mm
Depth	595	mm
Height	438	mm
Weight	56	kg

2.4 Technical data

Physical Characteristics

Width	165 mm
Depth	595 mm
Height	438 mm
Weight	56 kg

Electrical Characteristics

Battery type	LFP
Total Energy Capacity	5.12kWh
Usable Energy Capacity	4.60kWh
Battery Capacity (Nominal)	100Ah
Nominal Voltage	51.2V
Usable Voltage Range	48~57.6V
Charge Current (Recommended)	50A
Discharge Current (Recommended)	50A
Max. Continuous Charge Current	100A
Max. Continuous Discharge Current	100A
DOD	90%
Internal resistance	≤60mΩ
Cycle life @ 25°C (under standard charge and discharge conditions, charge 0.2C, discharge 0.2C)	≥6000
DC Disconnect	Contactor Fuse

Warranty

Please refer to SOLUNA WARRANTY CONDITIONS

BMS

Power consumption	<3W (work), <100mW (sleep)
Monitoring parameters	System Voltage System Current Cell Voltage Cell temperature
Communication	CAN
Protection	Over voltage Under Voltage Over current Over temperature Under temperature

System Configuration

Module parallel	1~12 Parallel
-----------------	---------------

Operating Conditions

Installation Location	Indoor Outdoor
Operating Temperature	-10~50 °C
Operating Temperature (Recommended)	15~30 °C
Storage Temperature	-20~60 °C
Humidity	5%~95%
Altitude	Max. 2,000 m
Cooling Strategy	Natural Convection

Reliability & Certification

Certificates	Cell: UL1642
	Battery Module: TBD
Transportation	UN38.3
Ingress Rating	IP54

2.5 Appearance

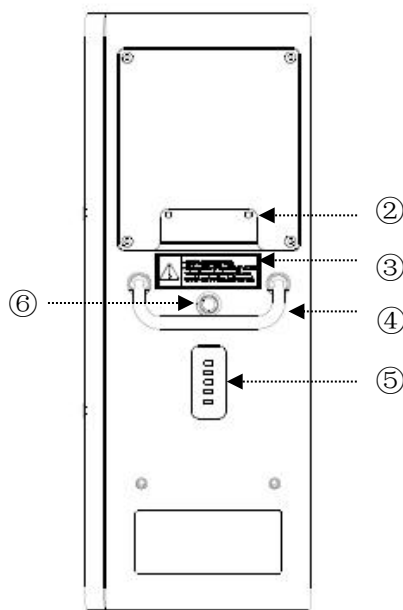
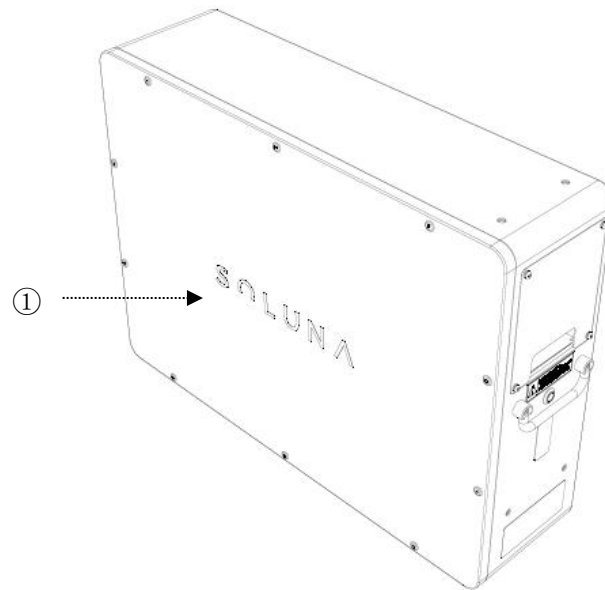

Figure 2.2 Appearance

Number	Name	Remark
①	Logo	
②	Entry	
③	Warning label	
④	Handle	
⑤	Battery capacity & warning indicator light	
⑥	Push button switch of BMS power supply	

2.6 Wring port

User can see the wiring port of Soluna EOS-5K Pack after the cover plat is opened, Please find the following pictures for details.

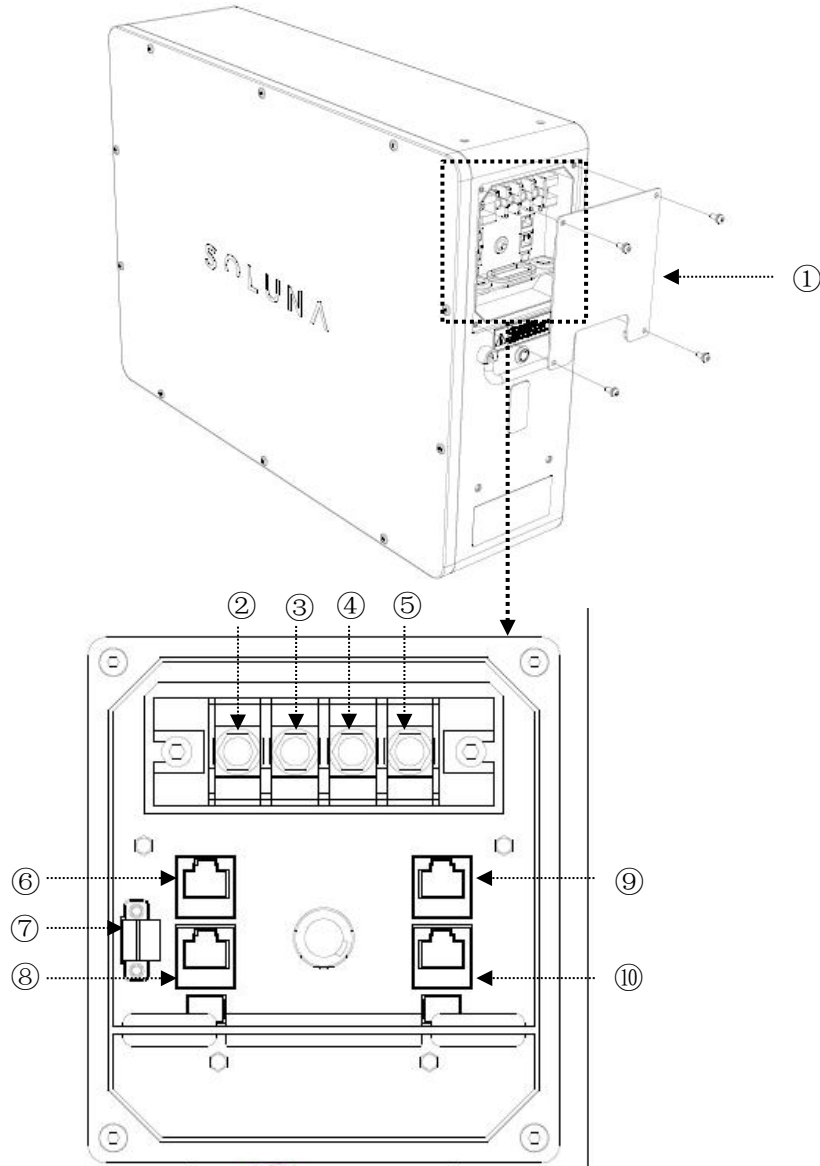

Figure 2.3 wiring port

Number	Name	Remark
①	Cover plat	
②③	Battery+	Positive pole of battery
④⑤	Battery-	Negative pole of battery
⑥⑧	CAN1 port	For BMS parameters monitoring
⑨⑩	CAN2 port	For inverter communication
⑦	Remote port	Power switch of BMS power supply

2.7 CAN communication interface definition (CAN1&CAN2)

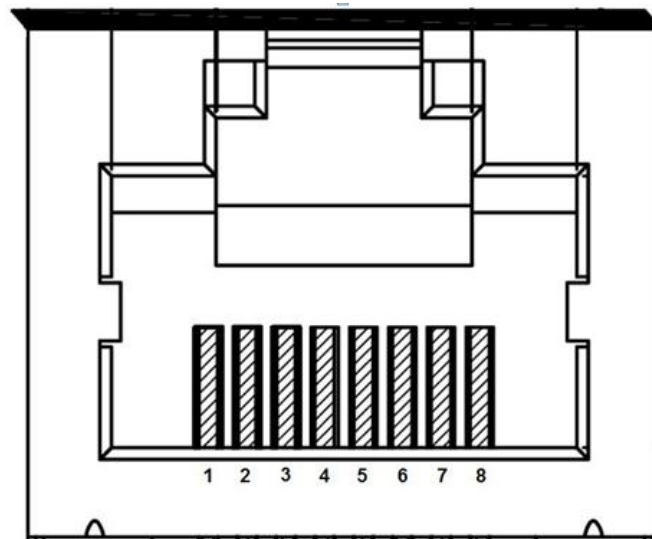

Figure 2.4 CAN interface definition

1	2	3	4	5	6	7	8
—	—	—	CANH	CANL	—	—	—

Remark

CAN1 is used for BMS parameters monitoring

CAN2 is used for inverter communication

2.8 LED lights definition

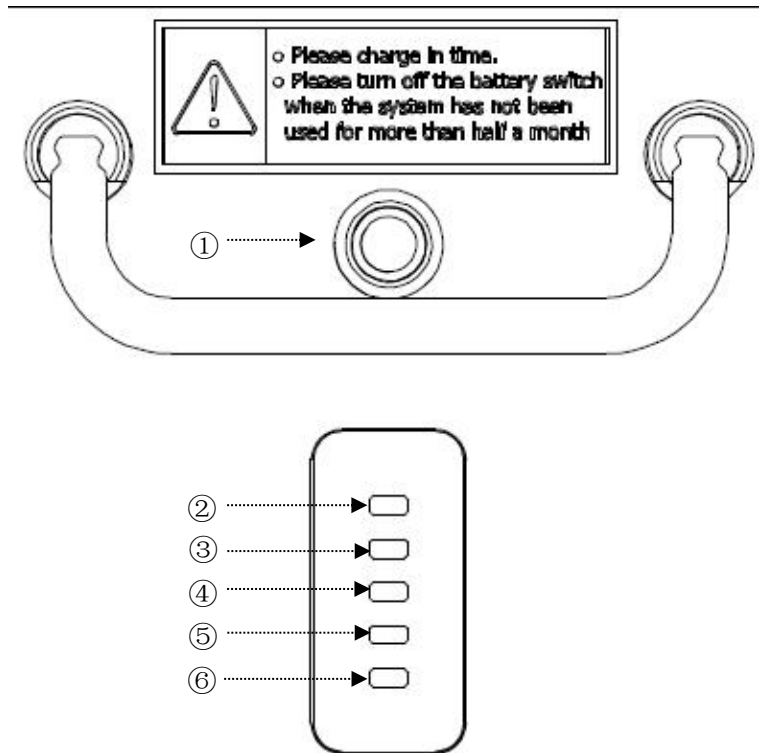

Figure 2.4 LED lights definition

Number	Name	Remark
①	Push button switch	White light
②	100% capacity indicator	Green light
③	75% capacity indicator	Green light
④	50% capacity indicator	Green light
⑤	25% capacity indicator	Green light
⑥	Warning indicator	Yellow light

Remark: Please see below information for Indicator running state.

- a. Push button switch-----The white light will be on after pressing the button.
- b. Warning indicator-----light is always on if there is no alarm, the light will blink if the Soluna EOS-5K Pack has any warning.

3 Installation



The battery pack is too heavy for one to carry. Make sure that two or more persons are available.

3.1 Unpacking the package

3.1.1 Cut the packing tape and open the carton, and remove the EPE foam.

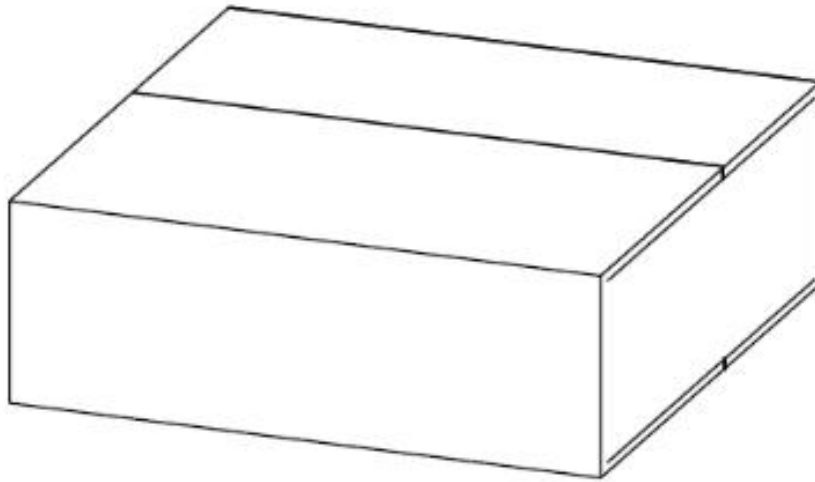

3.1.2 Pull out the battery pack, and remove the Scaleboard、PE bag、Carton、EPE Foam.

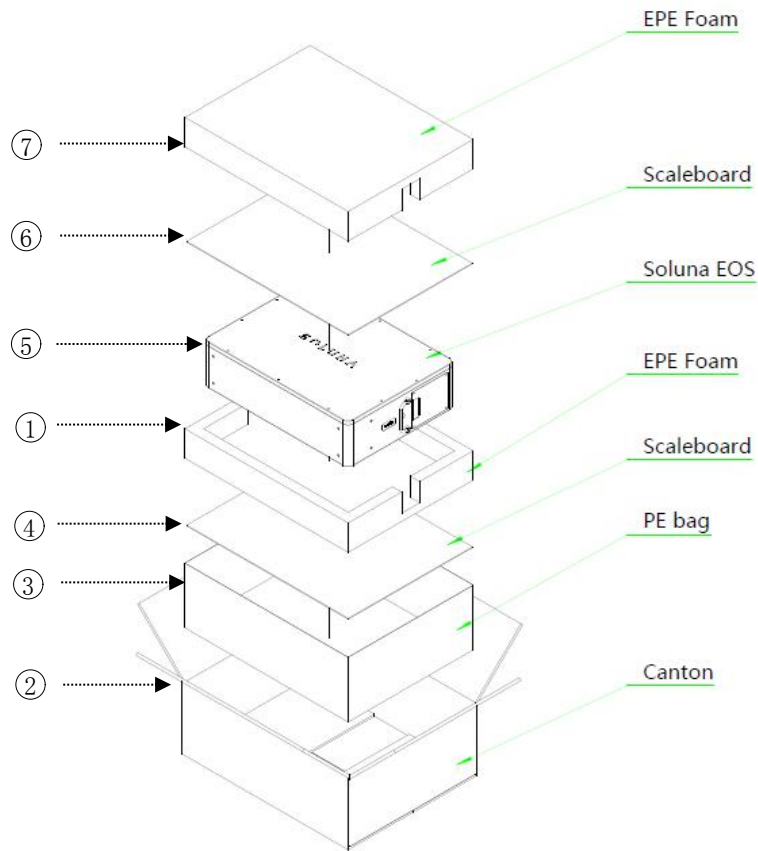

Number	Name	Remark
①④	EPE foam	
②⑤	Scaleboard	
③	Soluna EOS-5K Pack	
⑥	PE bag	
⑦	Carton	

3.2 Packing lists

The following table lists the numbers of each item included. If anything is damaged or missing, contact SOLUNA or your distributor.

Item	Name	Qty (pcs)	Remark
1	Soluna EOS-5K Pack	1	
2	U box accessory	1	
3	Screws-M6*10	6	
4	Screws-M4*8	2	
5	Screws-M6*16	4	
6	Wrench	1	
7	Communication cable(2m)	1	
8	Communication cable(0.5m)	2	
9	User manual	1	

3.3 Installation materials

These installation materials shall be prepared by installers.

- Charging cables
- Network cable

3.4 Installation location

We recommend that Soluna EOS-5K Pack is used in Soluna Home energy storage systems, if not, please Make sure that the installation location meets the following conditions:

- The building is designed to withstand earthquakes.
- The location is far away from the sea, to avoid salt water and humidity.
- The floor is flat and level.
- There are no flammable or explosive materials nearby.
- The ambient temperature is between 15 and 30°C.
- The temperature and humidity stays at a constant level.
- There is minimal dust and dirt in the area.
- There are no corrosive gases present, including ammonia and acid vapor.





If the ambient temperature is outside the operating range, the battery pack stops operating to protect itself. The optimal temperature range

	for the battery pack to operate is 15°C to 30°C. Frequent exposure to harsh temperatures may deteriorate the performance and lifetime of the battery pack.
--	--

3.5 Installation tools

The following tools are required to install the battery pack:

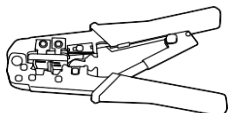
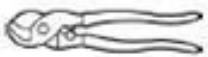
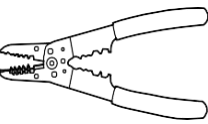
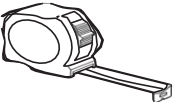

Item	Photo	Name
1		Phillips-screwdriver bit
2		Hexagon wrench
3		Network crimper
4		Wire cutters
5		Wire stripper
6		Tape measure

Remark:

Use properly insulated tools to prevent accidental electric shock or short circuits.

3.6 Safety gear

Wear the following safety gear when dealing with the battery pack. Installers must meet the relevant requirements of international standards, such as IEC 60364, or the domestic legislation.

Item	Photo	Name
1		Insulated gloves
2		Safety goggles
3		Safety shoes

3.7 Wiring specification

In order to standardize the wiring specification of Soluna EOS-5K Pack, the following requirements are required for connecting wires of Soluna EOS-5K Pack.

Battery wire	Communication cable	Remote wire
It is recommended to use 16 mm ² of conductor with double insulation	It is recommended to use Standard communication cable with shielding function	It is recommended to use 0.5 mm ² of Teflon wire

3.8 CAN communication wiring

3.8.1. Single battery unit

CAN2 is connected to inverter with communication cable.

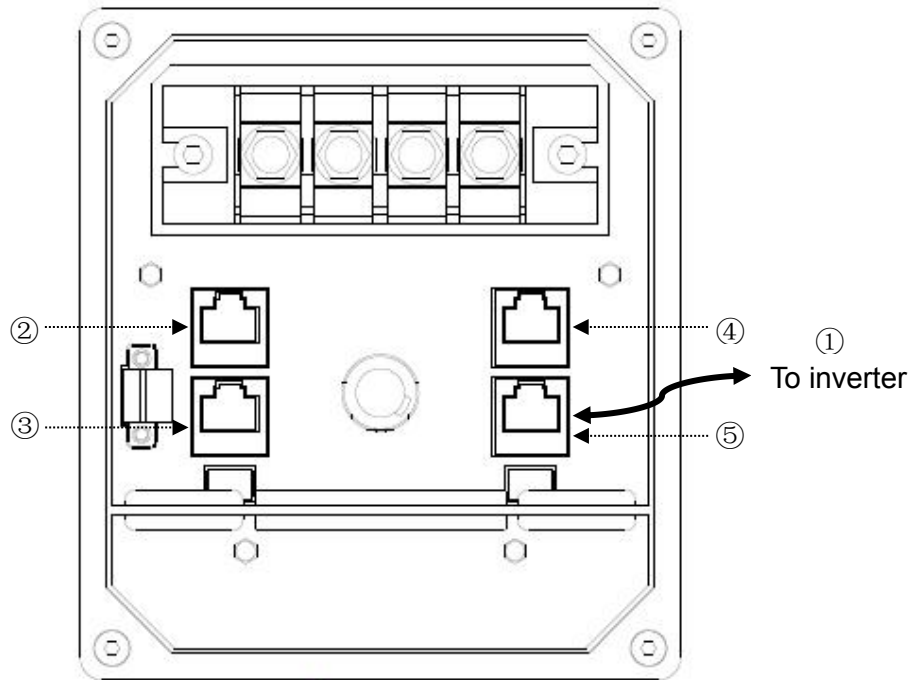

Figure 3.3 CAN communication wiring

Number	Name	Remark
①	Communication cable	
②③	CAN 1 port	PIN4 is CANH PIN5 is CANL
④⑤	CAN2 port	PIN4 is CANH PIN5 is CANL

3.8.2 The battery units are connected in parallel

Unit1:CAN1 is connected to Unit2:CAN1 with communication cable

Unit1:CAN2 is connected to Unit2:CAN2 with communication cable

Unit2:CAN2 is connected to inverter with communication cable

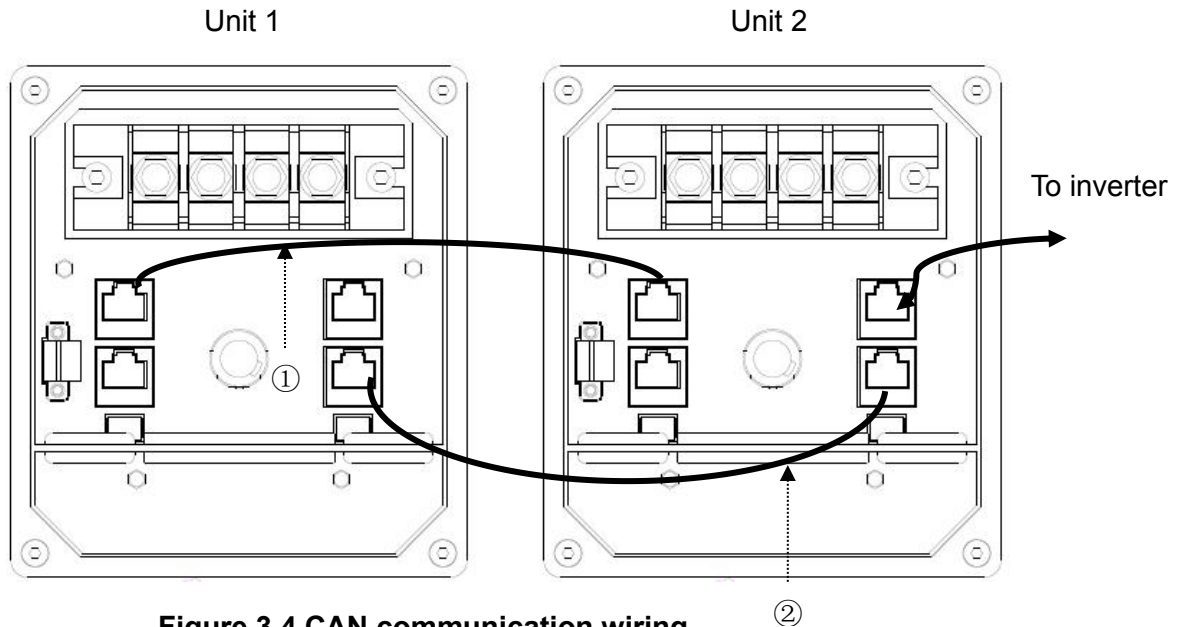

Figure 3.4 CAN communication wiring

Number	Name	Remark
①	Network cable	

4.How to operate Soluna EOS-5K Pack

There are two ways to start Soluna EOS-5K Pack, Please see below information for details.

4.1 Way 1

Short PIN2 & PIN3 of Remote port first then press the Metal button switch, the Soluna EOS-5K Pack will start to work within 25 seconds, it will stopped to output if there has no communications after 5 minutes

4.2 Way 2

Install a switch between PIN1 and PIN2 on the Remote port, when the switch on, the Soluna EOS-5K Pack will start to work within 25 seconds, it will stopped to output if there has no communications after 5 minutes

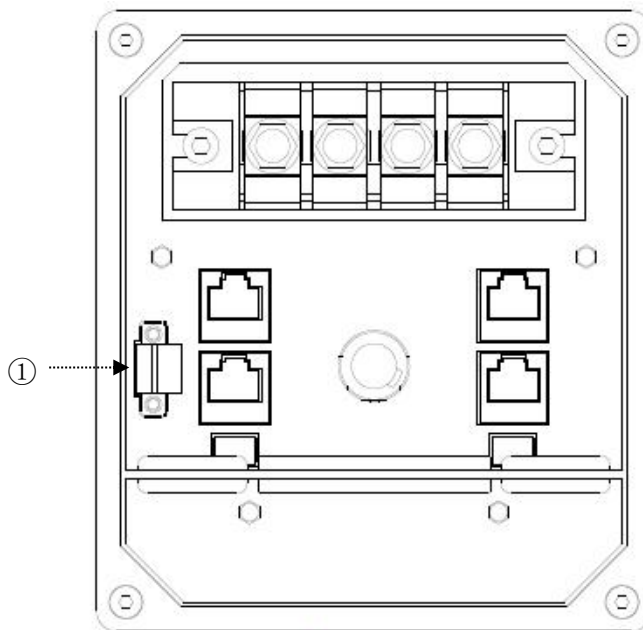

Figure 4.1 Remote port

Number	Name	Remark
①	Remote port	

5. Electrical connection

There are 2 ways to connect the battery with the inverter. The details as follows.

5.1 Single unit is connected to the inverter, Please find the following diagram for details.

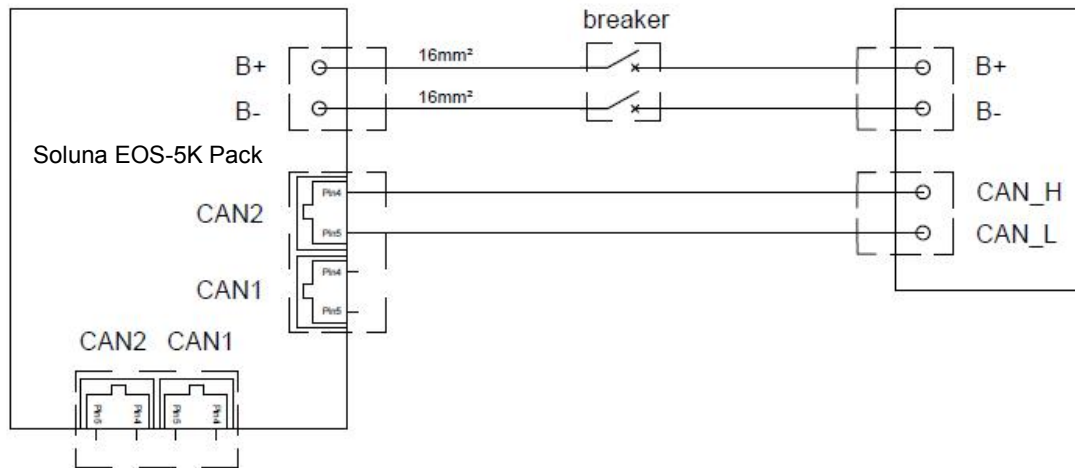

5.2 Multiple units are connected to the inverter, Please find the following diagram for details.

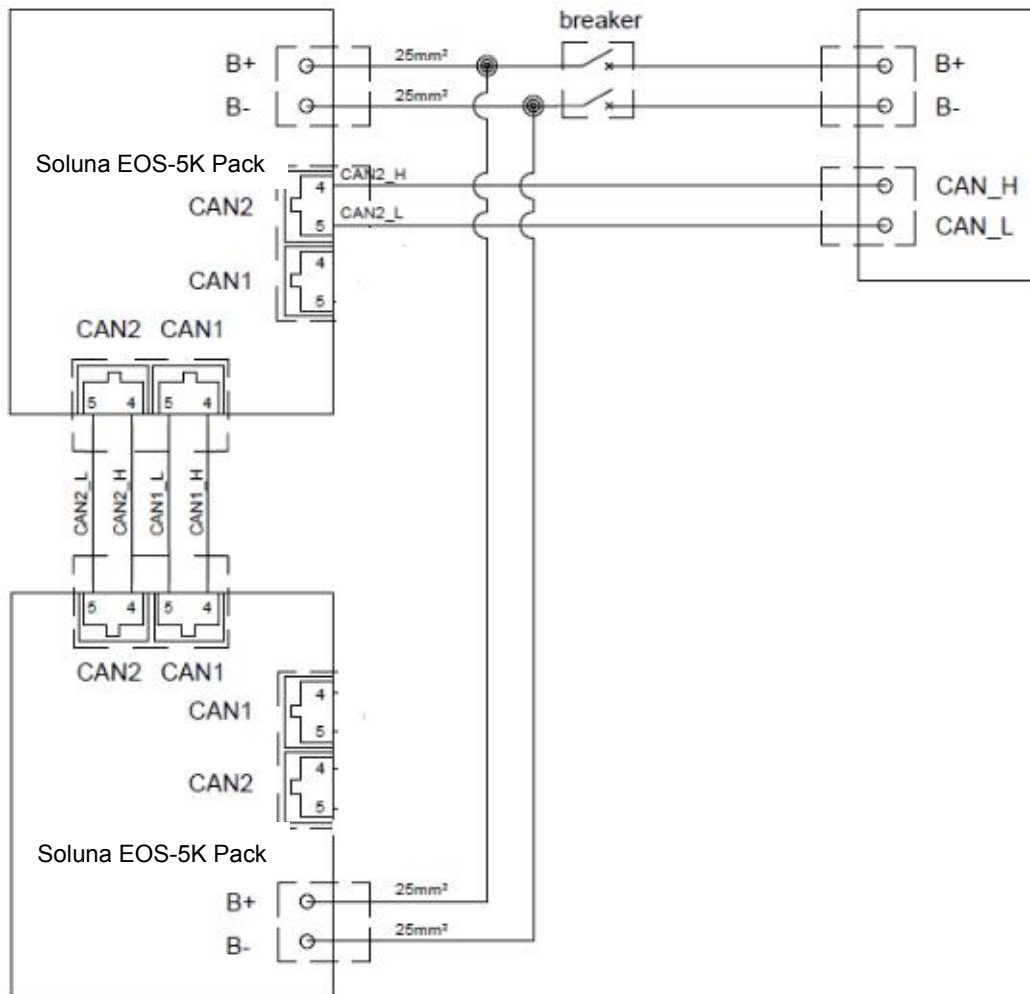

6 Troubleshooting

Check the indicators on the front to determine the state of the battery pack. a warning state is triggered when a condition, such as with voltage or current or temperature, is beyond design limitations. The battery pack's BMS periodically reports its operating state to the inverter. when the battery pack falls outside prescribed limits, it enters a warning state. When a warning is reported, the inverter immediately stops operation. use the monitoring software on the inverter to identify what caused the warning. The possible warning messages are as follows:

Battery Over Voltage

Battery Under Voltage

Battery Over Temperature

Battery Under Temperature

Battery Discharge Over Current

Battery Charge Over Current

The abnormal state is cleared when the battery pack recovers normal operation.

7 Contact us

We hope that this user manual has clearly demonstrated the product. If you still have any doubts or something not clear about it in the specifications, feel free contact to us please. we will do our best to support you!

SOLUNA (Shanghai) Co., Ltd

Add: No.3492 Jinqian Road, Shanghai, China 201406

Tel: +86-21-57475835

Email: sales@solunabattery.com

Web: www.solunabattery.com