

SOLUNA
POWER DESIGNED FOR NIGHT AND DAY

User Manual
Lithium Battery System
Soluna HV Ultra X Series
A.0

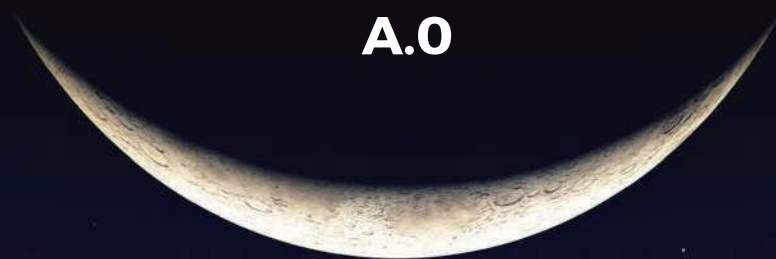

About this Specification

This manual provides comprehensive instructions for installing the Soluna HV Ultra X Series system battery. It is imperative to thoroughly read this manual before attempting to install the product and to follow the instructions diligently throughout the installation process.

If you have any doubts about the requirements, recommendations, or safety procedures described in this manual, please contact Soluna immediately for advice and clarification.

The information contained in this manual is accurate at the time of publication. However, due to ongoing updates to product design and technical specifications, our company reserves the right to make changes at any time without prior notice. Additionally, the illustrations included in this manual are intended to aid in explaining system configuration concepts and installation instructions. The items depicted in the illustrations may differ from the actual items at the installation site.

SOLUNA (SHANGHAI) CO.,LTD reserves the copyright of this document.

1. Introduction.....	05
2. Features.....	06
2.1 Features.....	06
2.2 Application.....	06
3. Safety Precautions.....	07
3.1 Warning Sign.....	07
3.2 Safety Instructions.....	08
3.2.1 Risks of Explosion.....	08
3.2.2 Risks of fire	08
3.2.3 Risks of electric shock	08
3.2.4 Risks of damage to the battery pack	08
3.3 Battery handling guide.....	09
3.4 Response to emergency situations.....	09
3.4.1 Leaking batteries	09
3.4.2 Inhalation.....	09
3.4.3 Eye contact.....	09
3.4.4 Skin contact.....	09
3.4.5 Ingestion.....	10
3.4.6 Fire.....	10
3.4.7 Wet batteries.....	10
3.4.8 Damaged batteries	11
3.5 Qualified installers.....	11
4. Appearance.....	12
5. Technical parameters.....	14
6. Connection Port	16
7. COM Communication Interface Definition	18
8. LED Lights Definition.....	27
9. Operation instructions.....	31
9.1 Check before starting up.....	31
9.2 Startup	31
10. Status indicator light introduction.....	32
11. Maintenance and troubleshooting.....	33
11.1 Maintenance	33
11.2 Troubleshooting	33

Contents

12. Depth of Discharge (DOD) Setting for inverter.....	36
13. Register on the Website after Installation	37
14. Contact us.....	38

1 Introduction

The Soluna HV Ultra system battery is an advanced LFP lithium battery product designed to meet the highest standards of performance and safety. Equipped with a sophisticated Battery Management System (BMS), this low-voltage battery module features CAN/RS485 communication for seamless integration and monitoring. It includes comprehensive protections against under-voltage, over-voltage, over-current, over-temperature, and under-temperature, ensuring optimal performance and safety under various conditions.

With its high energy density, long lifespan, and robust reliability, the Soluna HV Ultra series battery stands out as a green environmental product you can trust. Its innovative design not only enhances efficiency but also contributes to sustainability, making it an ideal choice for Backup Power, Micro-grid Solutions, and Small Industrial & Commercial Energy Storage Systems.

2.1 Features

- **Excellent Safety Performance**
Ensures the highest level of safety under various conditions.
- **Long Cycle Life**
Designed for extended usage without significant performance degradation.
- **Support for CAN-communication**
Provides support for CAN-based communication between devices.
- **High energy density**
Features high energy density for efficient power storage.
- **Excellent battery management system**
Equipped with an excellent battery management system (BMS) for safety and efficiency.
- **Number of expandable battery module, at least 2, up to 5**
Supports 2 to 5 expandable battery modules.
- **Wi-Fi monitor**
Wi-Fi monitoring supported.
- **Active balancing function, manage the consistency of batteries more efficiently**
Active balancing function for efficient battery consistency management.
- **Built-in fire extinguishing device**
Built-in fire extinguishing device for enhanced safety.
- **Small size and light weight, easy installation and maintenance of standard module**
Compact and lightweight design for easy installation and maintenance.













2.2 Application

- Back-up power
- Micro-grid
- Home Energy Storage system

3 Safety Precautions

3.1 Warning Signs

Warning signs are essential indicators designed to alert you to conditions that could result in severe injury or significant damage to the device. They serve as critical reminders to exercise caution and take necessary precautions to prevent hazardous situations. The table below outlines the warning signs used in this manual and their meanings:

Sign	Description
	High Voltage Warning: This battery pack operates at high voltage, which can cause severe injury due to electric shock.
	Correct Polarity: Ensure the battery polarity is correctly connected.
	Fire Safety: Keep the battery pack away from open flames or ignition sources.
	Child Safety: Store the battery pack out of reach of children.
	Installation Manual: Thoroughly read the manual before installing and operating the battery pack.
	Heavy Weight Warning: The battery pack is heavy, and improper handling may result in severe injury. Utilize proper lifting techniques.
	Electrolyte Leakage: The battery pack may leak corrosive electrolyte. Handle with care and adhere to appropriate safety procedures.
	Explosion Risk: The battery pack may explode under certain conditions.
	Disposal Instructions: Do not dispose of the battery pack with household waste at the end of its working life. Follow local regulations for disposal.
	Compliance Requirement: Failure to follow the provided requirements and guidelines may lead to physical injury or damage to the device.
	Do not short circuit.
	Grounding conductor This symbol indicates the position for connecting a grounding conductor.

3.2 Safety Instructions

For safety reasons, it is crucial that installers thoroughly familiarize themselves with the contents of this manual and all associated warnings prior to commencing the installation.



General Safety Precautions

Failure to adhere to the precautions outlined in this section can result in serious injury or property damage. Please observe the following safety guidelines:

3.2.1 Risks of Explosion

- Avoid subjecting the battery pack to strong impacts.
- Do not crush or puncture the battery pack.
- Never dispose of the battery pack in a fire.

3.2.2 Risks of Fire

- Do not expose the battery pack to temperatures exceeding 60°C.
- Keep the battery pack away from heat sources, such as fireplaces.
- Avoid exposing the battery pack to direct sunlight.
- Ensure the battery connectors do not come into contact with conductive objects like wires.

3.2.3 Risks of Electric Shock

- Refrain from disassembling the battery pack.
- Do not touch the battery pack with wet hands.
- Keep the battery pack away from moisture or liquids
- Ensure the battery pack is kept away from children and animals.

3.2.4 Risks of Damage to the Battery Pack

- Do not allow the battery pack to come in contact with liquids.
- Do not subject the battery pack to high pressures.
- Do not place any objects on top of the battery pack.

3.3 Battery Handling Guide

- Use the battery pack only as directed.
- Do not use the battery pack if it appears defective, cracked, broken, or fails to operate correctly.
- Do not attempt to open, disassemble, repair, tamper with, or modify the battery pack as it is not user serviceable.
- Handle the battery pack with care during transportation to avoid damage.
- Avoid impacting, pulling, dragging, or stepping on the battery pack.

3.4 Response to Emergency Situations

The Soluna HV Ultra X Series battery pack comprises multiple batteries that are designed to prevent hazards resulting from failures. However, Soluna cannot guarantee their absolute safety.

3.4.1 Leaking Batteries

If the battery pack leaks electrolyte, avoid contact with the leaking liquid or gas. The electrolyte is corrosive and contact may cause skin irritation and chemical burns. If someone is exposed to the leaked substance, do these actions:

3.4.2 Inhalation

- Evacuate the contaminated area immediately.
- Seek medical attention without delay.

3.4.3 Eye Contact

- Rinse eyes with flowing water for at least 15 minutes.
- Seek medical attention immediately.

3.4.4 Skin Contact

- Wash the affected area thoroughly with soap and water.
- Seek medical attention immediately.

3.4.5 Ingestion

- Induce vomiting.
- Seek medical attention immediately.

3.4.6 Fire Response Procedures

In the event of a fire, always have an ABC or carbon dioxide extinguisher on hand.



The battery pack may ignite if heated above 150 °C. If a fire occurs where the battery pack is installed, follow these steps:

- **Extinguish Early**

Attempt to extinguish the fire before the battery pack ignites.

- **Safe Relocation**

If extinguishing is not possible but time allows, move the battery pack to a safe area before it catches fire.

- **Evacuate**

If the battery pack has already caught fire, do not attempt to extinguish it. Evacuate the area immediately.



Caution: If the battery catches fire, it will emit noxious and poisonous gases. Do not approach the fire.

3.4.7 Wet Batteries

If the battery pack becomes wet or submerged in water, do not attempt to access it. Contact Soluna or your distributor for technical assistance immediately.

3.4.8 Damaged Batteries

Damaged batteries are hazardous and must be handled with extreme caution. They are unfit for use and may pose a danger to people or property.

If the battery pack appears damaged, pack it in its original container and return it to Soluna or your distributor.



Leakage and Flammability: Damaged batteries may leak electrolyte or produce flammable gas. If you suspect such damage, contact Soluna for advice and information immediately.

3.5 Qualified Installers

This manual, along with the tasks and procedures described herein, is intended for use by skilled professionals only. A skilled professional is defined as a trained and qualified electrician or installer who possesses all of the following skills and experience:

- **Functional Knowledge**

Understanding of the principles and operation of on-grid systems.

- **Risk Awareness**

Awareness of the dangers and risks associated with installing and using electrical devices and the acceptable methods for mitigating these risks.

- **Installation Proficiency**

Expertise in the installation of electrical devices.

- **Adherence to Guidelines**

Knowledge of and compliance with this manual, including all safety precautions and best practices.

- **Battery Maintenance**

Only authorized personnel should perform maintenance. Turn off the battery before maintenance. Periodically check voltage, SOC, and cables for damage or wear. Perform balancing maintenance (fully charge) every three months.

- **Installation Environment Requirements**

Avoid flammable, explosive, or corrosive materials. Keep out of children's reach and avoid high temperatures. Ensure proper ventilation and avoid electromagnetic interference. Install in a sheltered, well-ventilated area, within the appropriate temperature and humidity range, and below 2000 meters altitude.

4.1 Soluna Ultra System introduction

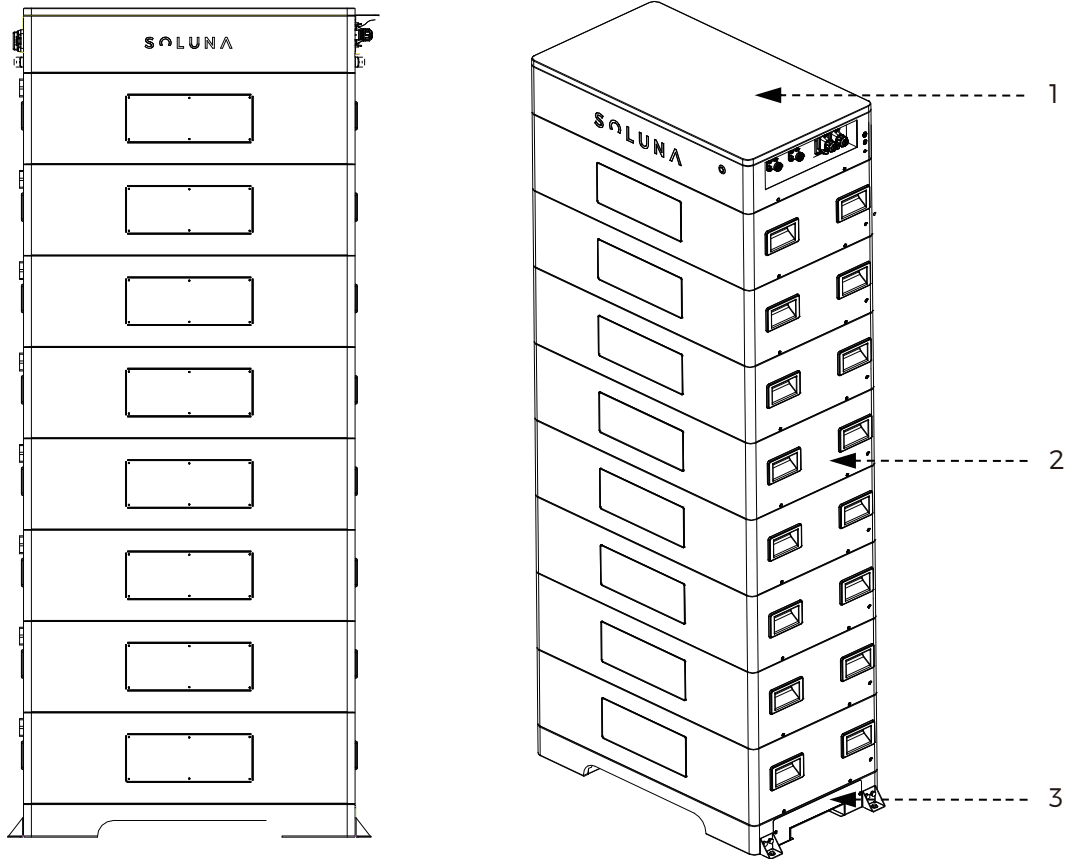

Number	Name	Description
1	Soluna HV Ultra X Series BMU	include high Voltage Box with Base
2	Soluna HV Ultra X Series Module	57.6VDC / 314Ah
3	Soluna HV Ultra X Series Base	

4.2 Soluna HV Ultra X 18K Base introduction

Note: Please select the appropriate number of battery modules and BMUs according to your actual requirements when placing an order.

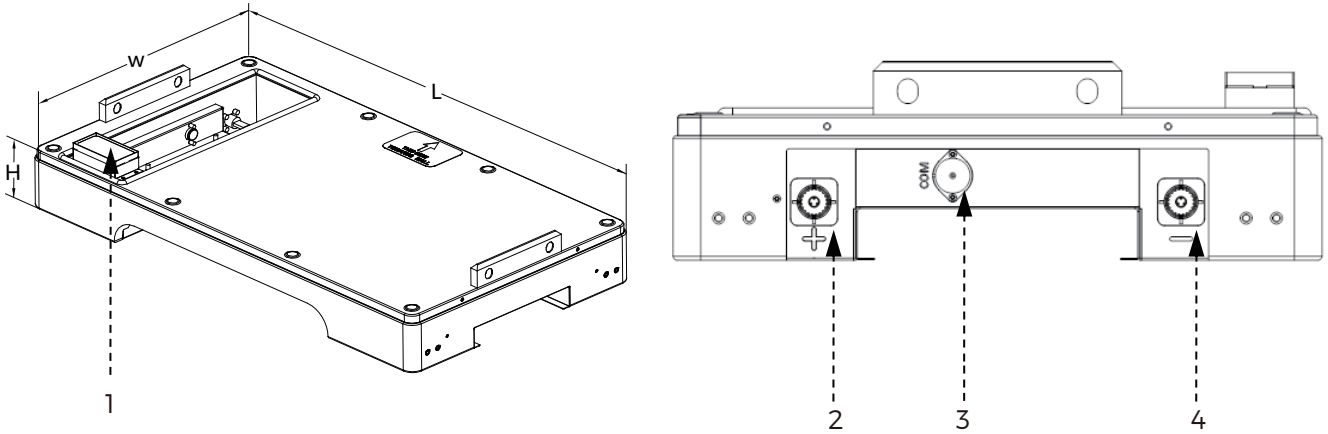

Width	840	mm
Depth	470	mm
Height	110	mm

Number	Name	Description
1	Stacked connector socket	Battery module series connection port
2	Positive Power Terminal	Positive input and output interface
3	COM	Battery module communication interface
4	Negative Power Terminal	Negative input and output interface

4 Appearance

4.2 Soluna HV Ultra X 18K module introduction

Note: Please select the appropriate number of battery modules and BMUs according to your actual requirements when placing an order.

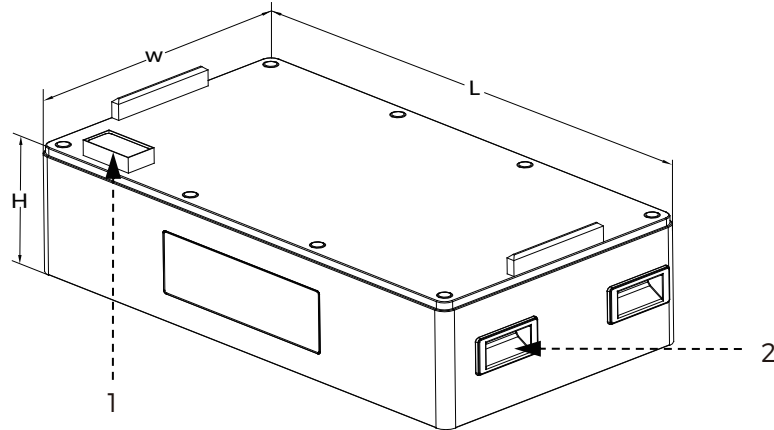

Width	840	mm
Depth	470	mm
Height	246	mm

Number	Name	Description
1	Stacked connector socket	Battery module series connection port
2	Hands	

4 Appearance

4.2 Main control module introduction

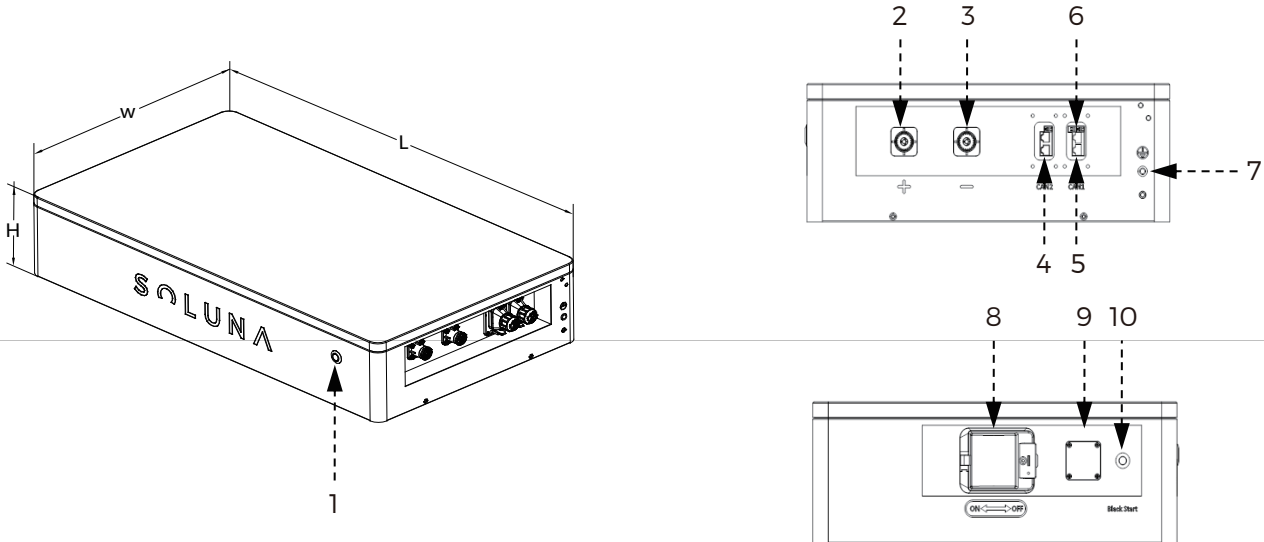

Number	Name	Description
1	LED light	Status indicator light
2	Positive Power Terminal	Positive input and output interface
3	Negative Power Terminal	Negative input and output interface
4	CAN2 port	For communicate between batteries
5	CAN1 port	For communicate with the inverter
6	DIP switch	For parallel terminal resistors
7	PE	Ground point
8	Breaker	For controlling the output and cutting off the battery voltage
9	Rotary switch	Under-voltage reverse gear protection function
10	Black Start button	Press and hold for about 10 seconds to output the battery voltage

5 Technical parameters

Model	Ultra X 72K	Ultra X 90K	Ultra X 108K	Ultra X 126K
Physical characteristics				
Dimensions (W * D * H) (mm)	840*465*1172	840*465*1403	840*465*1634	840*465*1865
Weight(kg)	560	690	820	950
Electrical characteristics				
Battery type	LFP			
Total Energy Capacity(kWh)	72	90	108	126
Usable Energy Capacity(kWh)	64.8	81	97.2	113.4
Battery Capacity (Nominal)(Ah)	314			
Voltage Range(Usable)(V)	201.6~252	252~315	302.4~378	352.8~441
Nominal Voltage(V)	230.4	288	345.6	403.2
Charge/Discharge Power (Nominal)(kW)	36	45	54	63
Max.Charge/Discharge Power (kW)	36	45	54	63
Charge/Discharge Current (Nominal)(A)	157A/157A			
Charge/Discharge Current (Max)(A)	157A/157A			
DOD	90%			
Round-Trip Efficiency	≥94%			
Self discharge @25°C	≤2%			
Cycle life (+0.5C/-0.5C, 25±2°C)	≥6000			
DC Disconnect	Contactor / Fuse			

5 Technical parameters

Model	Ultra X 144K	Ultra X 162K	Ultra X 180K	Ultra X 198K
Physical characteristics				
Dimensions (W * D * H) (mm)	840*465*1172+951	840*465*1172+1172	840*465*1403+1172	840*465*1403+1393
Weight(kg)	1080	1210	1340	1470
Electrical characteristics				
Battery type	LFP			
Total Energy Capacity(kWh)	144	162	180	198
Usable Energy Capacity(kWh)	129.6	145.8	162	178.2
Battery Capacity (Nominal)(Ah)	314			
Voltage Range(Usable)(V)	403.2~504	453.6~567	504~630	554.4~693
Nominal Voltage(V)	460.8	518.4	576	633.6
Charge/Discharge Power (Nominal)(kW)	72	81	90	99
Max.Charge/Discharge Power (kW)	72	81	90	99
Charge/Discharge Current (Nominal)(A)	157A/157A			
Charge/Discharge Current (Max)(A)	157A/157A			
DOD	90%			
Round-Trip Efficiency	≥96%			
Self discharge @25°C	≤2%			
Cycle life (+0.5C/-0.5C, 25±2°C)	≥6000			
DC Disconnect	Contactor / Fuse			

5 Technical parameters

Model	Ultra X 217K	Ultra X 235K	Ultra X 253K	Ultra X 271K
Physical characteristics				
Dimensions (W * D * H) (mm)	840*465*1634+1393	840*465*1634+1514	840*465*1855+1514	840*465*1855+1735
Weight(kg)	1600	1730	1860	1990
Electrical characteristics				
Battery type	LFP			
Total Energy Capacity(kWh)	216	234	252	270
Usable Energy Capacity(kWh)	194.4	210.6	226.8	243
Battery Capacity (Nominal)(Ah)	314			
Voltage Range(Usable)(V)	604.8~756	655.2~819	705.6~882	756~945
Nominal Voltage(V)	691.2	748.8	806.4	864
Charge/Discharge Power (Nominal)(kW)	108	117	126	135
Max.Charge/Discharge Power (kW)	108	117	126	135
Charge/Discharge Current (Nominal)(A)	157A/157A			
Charge/Discharge Current (Max)(A)	157A/157A			
DOD	90%			
Round-Trip Efficiency	≥96%			
Self discharge @25°C	≤2%			
Cycle life (+0.5C/-0.5C, 25±2°C)	≥6000			
DC Disconnect	Contactor / Fuse			

5 Technical parameters

Number of expandable battery units	10
Monitoring parameters	System Voltage , System Current , Cell Voltage Cell temperature , SOC , Insulation
Operating Conditions	
Condition	Indoor & outdoor conditioned
Operating Temperature (Charge/Discharge)	0~55°C / -20~55°C
Operating Temperature (Recommended)	15~30°C
Storage Temperature	-20~55°C
Humidity	5%~95%
Altitude	Max. 2,000 m
Cooling Strategy	Natural Convection
Reliability & Certification	
Certificates	TBD
Transportation	UN38.3
Ingress Rating	IP65
Physical Characteristics	
Please refer to SOLUNA WARRANTY CONDITIONS	

6 CAN communication interface definition

Once the cover plate of the Soluna HV Ultra X 18K is opened, users can view the connection ports of the battery. Please refer to the images below for detailed visuals.

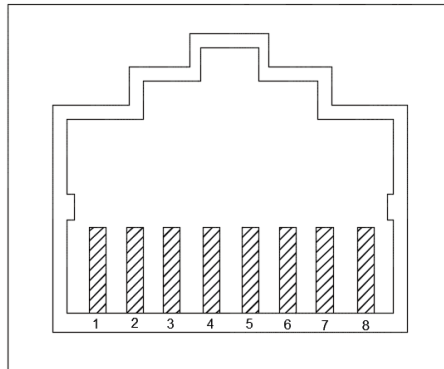

CAN1

1	2	3	4	5	6	7	8
—	—	—	CAN-H	CAN-L	—	—	—

CAN2

1	2	3	4	5	6	7	8
485A	485B	12V+	CAN-H	CAN-L	GND	CAN3H	CAN3L







Remark:

- 1) CAN1 is used for BMS parameters monitoring
- 2) CAN2 is used for Inverter communication

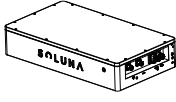
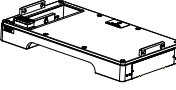

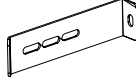
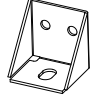
7.1 Packing List

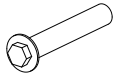
The following table lists the numbers of each item included. If anything is damaged or missing, contact SOLUNA or your distributor.



High-voltage box + standard base accessories

Item	Name	Description	Qty (pcs)	Photo
1	High Voltage Box	used for managing and protecting high-voltage power in the system.	1	
2	Standard Base	used for supporting and mounting the equipment.	1	
3	WiFi Base	used for providing WiFi connectivity for the system.	1	
4	Wall-Mount Bracket	used for mounting the equipment onto the wall.	4	
5	Angle Bracket	used for corner fixing and structural support of the equipment.	4	
6	Spacer	used for spacing and supporting components.	4	
7	Connection Cable	used for connecting system components.	1	
8	Expansion Bolt	used for wall or surface mounting of components.	10	
9	M5×12 Triple-Set Screw	used for triple-screw fastening of components.	2	
10	M6 × L12 Combination Screw	Used for fastening and securing components during installation.	15	

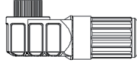

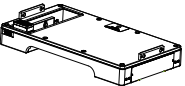
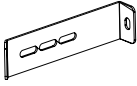
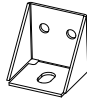

7 Installation

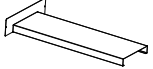
Item	Name	Description	Qty (pcs)	Photo
11	M4 × L12 Countersunk Screw	used for flush mounting and fastening components.	5	
12	Positive Quick Plug	used for quick and secure connection of the positive terminal.	1	
13	Negative Quick Plug	used for quick and secure connection of the negative terminal.	1	

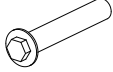

Series box + expansion base accessories

Item	Name	Description	Qty (pcs)	Photo
1	Series Connection Box	used for series connection and centralized management of battery modules.	1	
2	Expansion Base	used for module expansion and support.	1	
3	Wall-Mount Bracket	used for securely mounting components on the wall.	4	
4	Angle Bracket	used for corner fixing and structural support of the equipment.	4	
5	Spacer	used for spacing and supporting components.	4	
6	Series Connection Cable	used for connecting modules in series.	1	
7	Cable Duct	used for organizing and protecting cables.	1	

7 Installation

Item	Name	Description	Qty (pcs)	Photo
8	Expansion Screw	used for securing components to walls or solid surfaces.	10	
9	M6 × L12 Combination Screw	used for fastening and securing components during installation.	15	
10	M4 × L12 Countersunk Screw	used for flush mounting and fastening components.	5	
11	Series Communication Harness	used for connecting modules for communication in series.	1	
12	Series Power Cable	used for connecting modules for power in series.	1	

Module Accessories

Item	Name	Description	Qty (pcs)	Photo
1	M4 × L12 Countersunk Screw	used for flush mounting and fastening components.	5	
2	18K Module	used for installation and integration of 18K battery modules.	1	

7.2 Installation materials

These installation materials shall be prepared by installers.

- Charging cables
- Network cables
- DC breaker

7.3 Installation Location

We recommend that Soluna HV Ultra X 18K battery is used in Soluna Home energy storage systems, if not, please Make sure that the installation location meets the following conditions:

- The building is designed to withstand earthquakes.
- The location is far away from the sea, to avoid salt water and humidity.
- The floor is flat and level.
- There are no flammable or explosive materials nearby.
- The ambient temperature is between 15 and 30°C.
- The temperature and humidity stays at a constant level.
- There is minimal dust and dirt in the area.
- There are no corrosive gases present, including ammonia and acid vapor.
- The working temperature range: 0 ~50°C, optimum temperature: 15 ~30°C.



If the ambient temperature is outside the operating range, the battery pack stops operating to protect itself. The optimal temperature range for the battery pack to operate is 15°C to 30°C. Frequent exposure to harsh temperatures may deteriorate the performance and lifetime of the battery pack.

Notice:



Do not place the battery system in direct sun light. it is suggested to build sunshade equipment in cold area the heating system is required.

7.4 Installation Tools Requirements

The following tools are required to install the battery pack:

Remark:

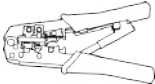
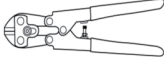
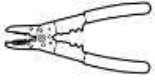
Use properly insulated tools to prevent accidental electric shock or short circuits.

Item	Photo	Name
1		Phillips-screwdriver bit
2		Network crimper
3		Wire cutters
4		Wire stripper
5		Tape measure
6		Drill

When handling the battery pack, it is essential to wear the appropriate safety gear to protect against potential hazards, installers must adhere to the relevant requirements of international standards, such as IEC 60364, or comply with domestic legislation.

1		Safety goggles
2		Safety shoes
3		Insulated gloves

7.5 Wiring Specification

In order to standardize the wiring specification of Soluna Soluna HV series battery, the following requirements are required for connecting wires of Soluna HV series battery.

Battery Wire	Communication Cable
It is recommended to use 1AWG (50mm ²) of conductor with double insulation	It is recommended to use standard communication cable with shielding function.

7.5 Install The Battery

Assembly Diagram for ≥ 8 Battery Modules

Step 1:

Following the operation steps, drill holes on the wall after calculating the positioning dimensions as shown in the figure (N represents the number of modules). Note: The maximum distance between two clusters should not exceed 500mm.

1. Use a 10 mm drill bit to drill into the wall at a 90° vertical angle, with a hole depth of no less than 70 mm.

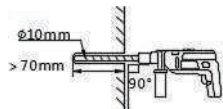

2. Tap the M6*60 expansion bolt into the hole with a hammer.

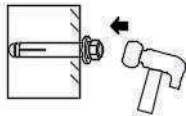

3. Tighten the expansion bolt.

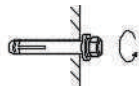

4. Remove the expansion bolt and keep it for backup.

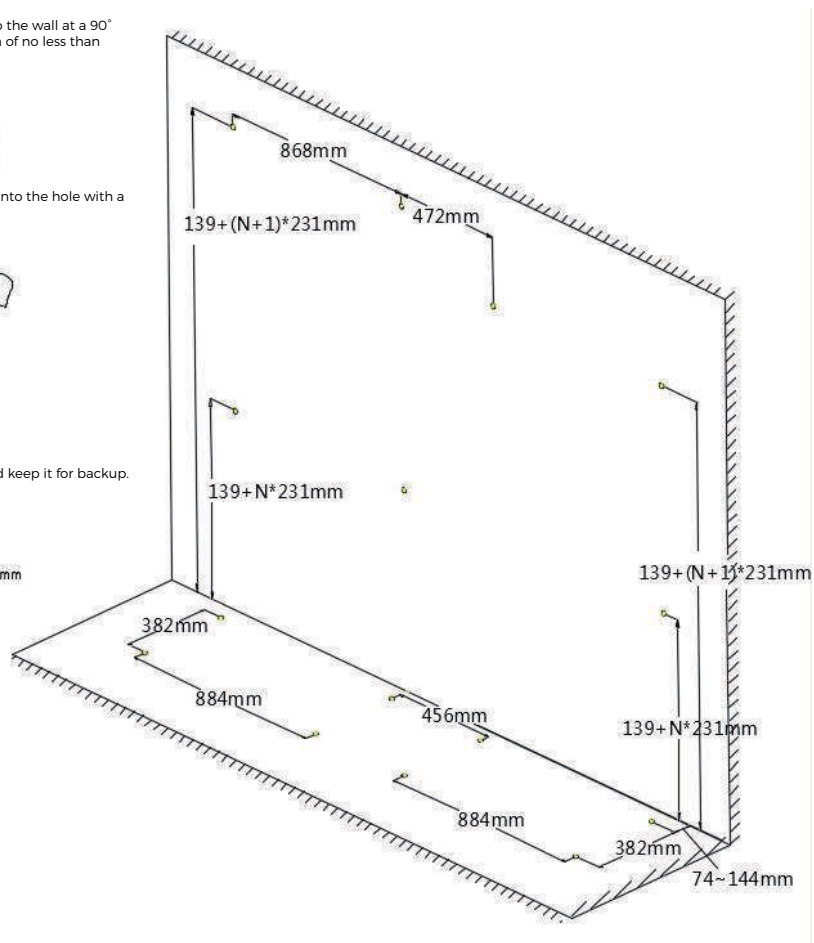
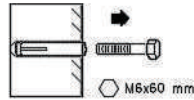

7.5 Install The Battery

Step 2:

During installation, first use the expansion screws (8 pieces in total) to preliminarily fix the two bases on the leveled floor positions. After completing the installation of all modules, tighten all screws uniformly.

Notes:

- The product orientation must match the wall-facing direction indicated in the figure.
- Each module weighs approximately 131kg. Before installation, ensure that the floor's load-bearing capacity meets the requirements.

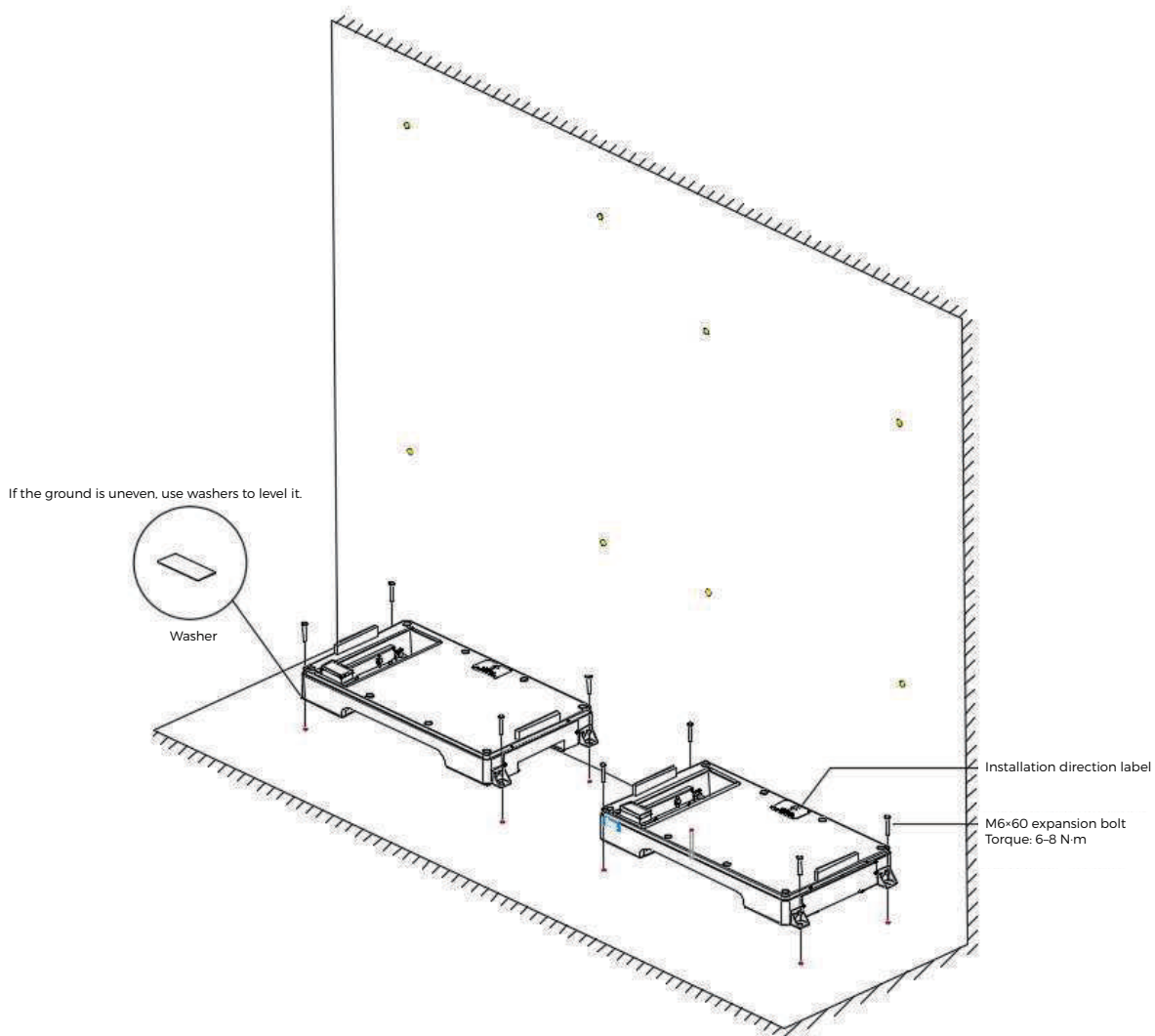

7.5 Install The Battery

Step 3:

Stack each module on the base as shown in the figure, then secure with 2 M4 countersunk screws on each side.

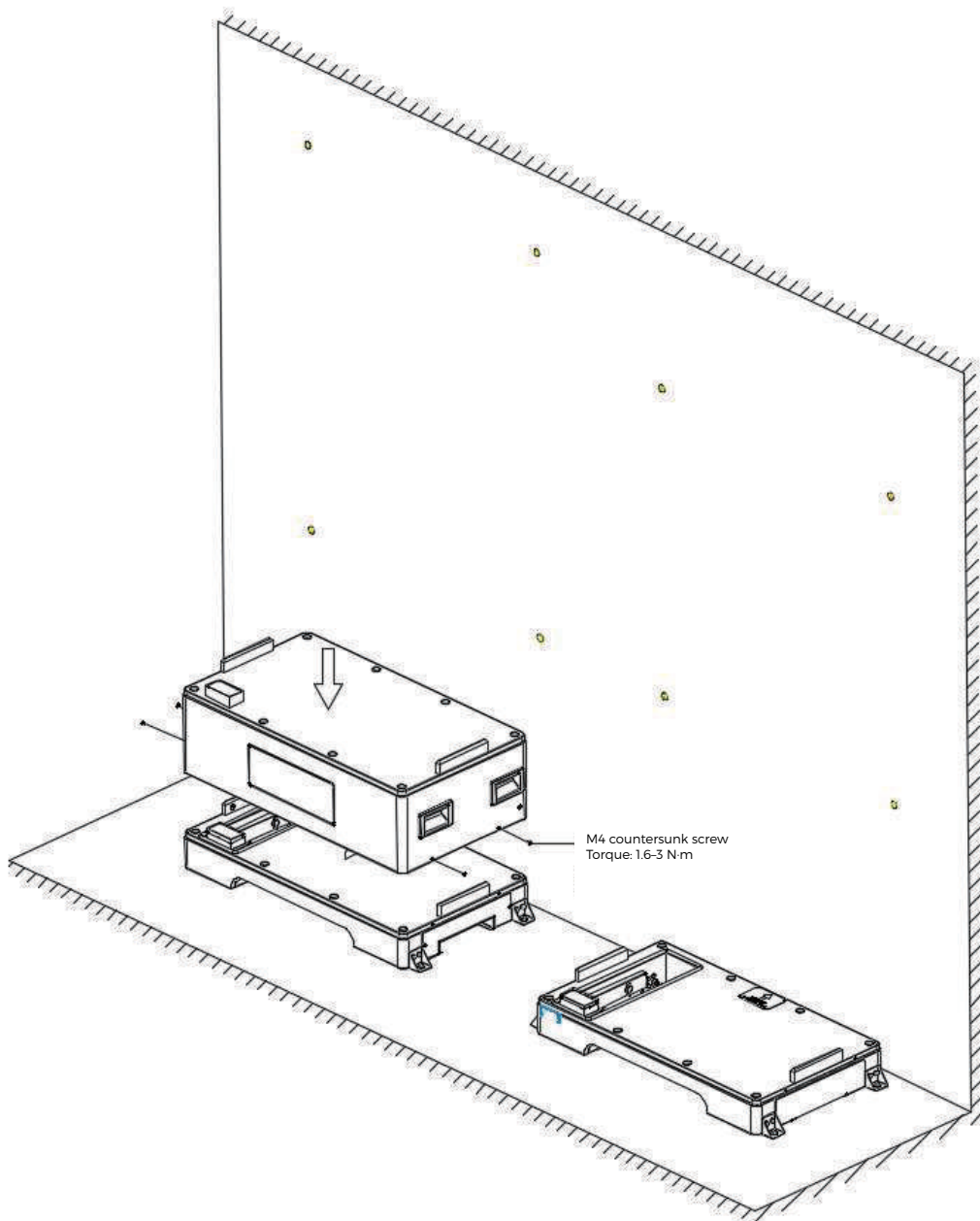

7.5 Install The Battery

Step 4:

Repeat Step 3 and stack modules layer by layer up to the 8th layer. Then install the series connection box as shown in the figure and secure it with 2 M4 countersunk screws on each side.

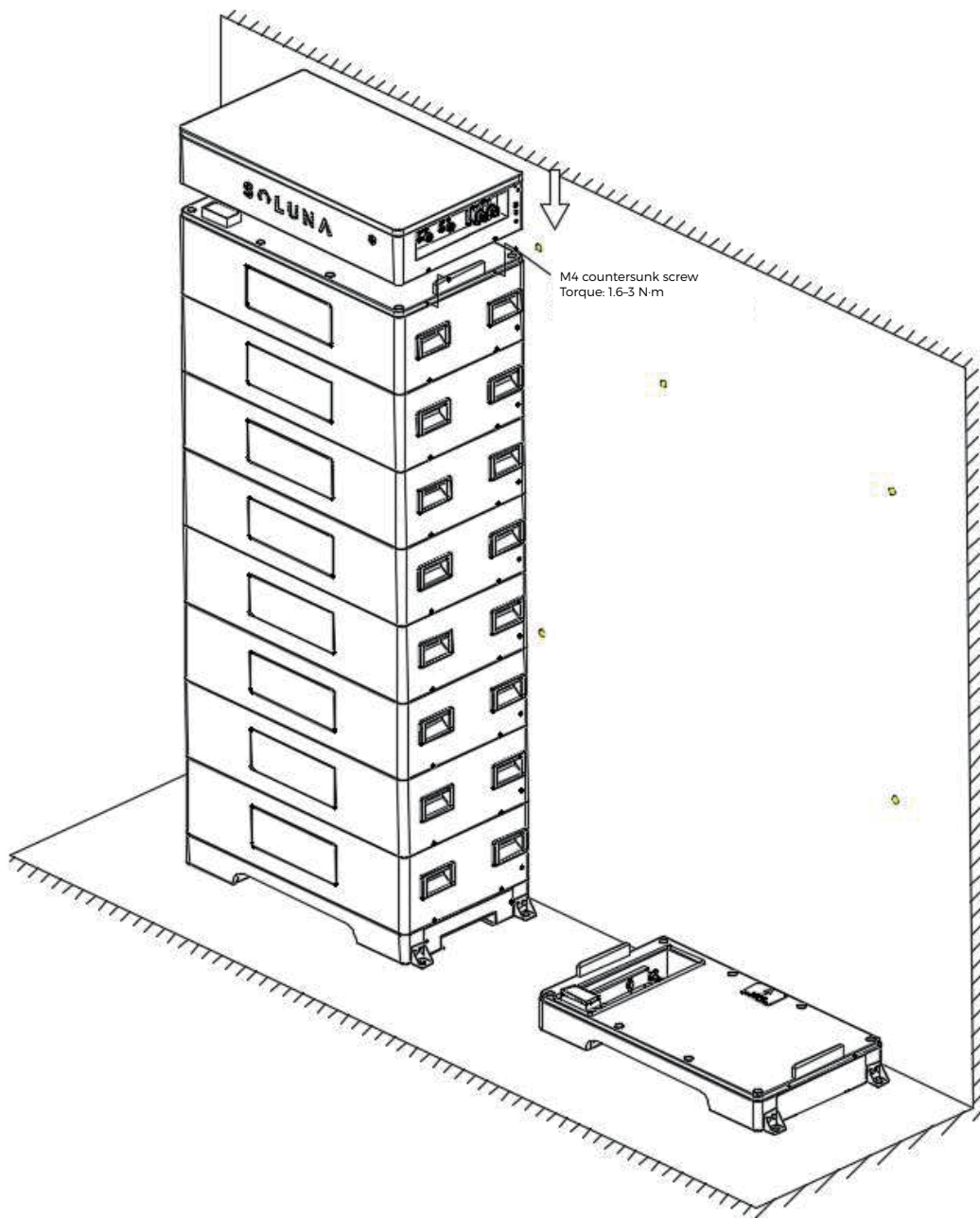

7.5 Install The Battery

Step 5:

Following the method in Step 3, continue stacking modules on the expansion base up to the 7th layer. Then install the series connection box on the top layer and secure it with 2 M4 countersunk screws on each side.

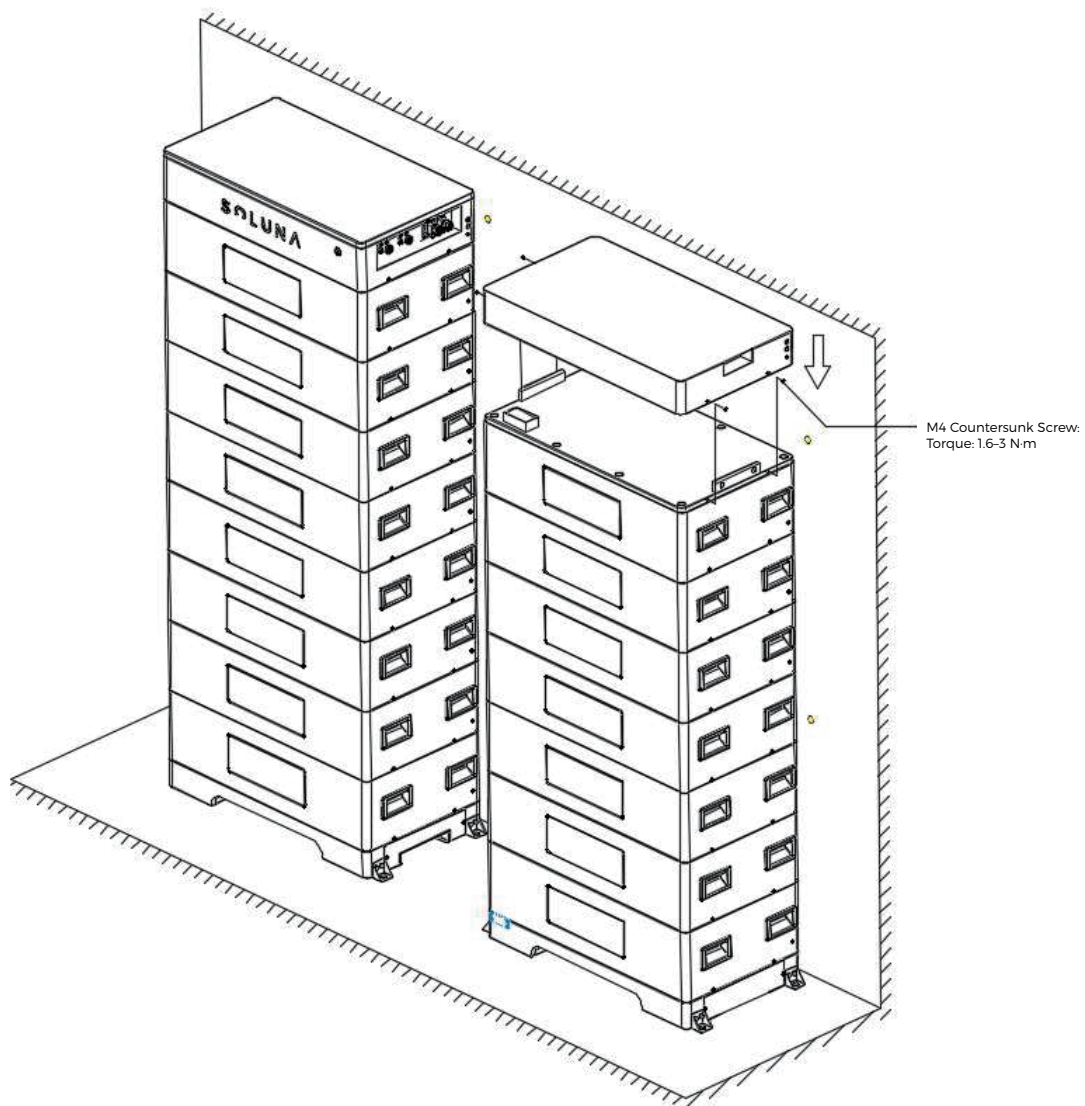

7.5 Install The Battery

Step 6:

After stacking the modules, refer to the figure and fix one end of the wall-mount bracket to the modules with an M6 screw, and the other end to the wall with an M6 expansion screw.

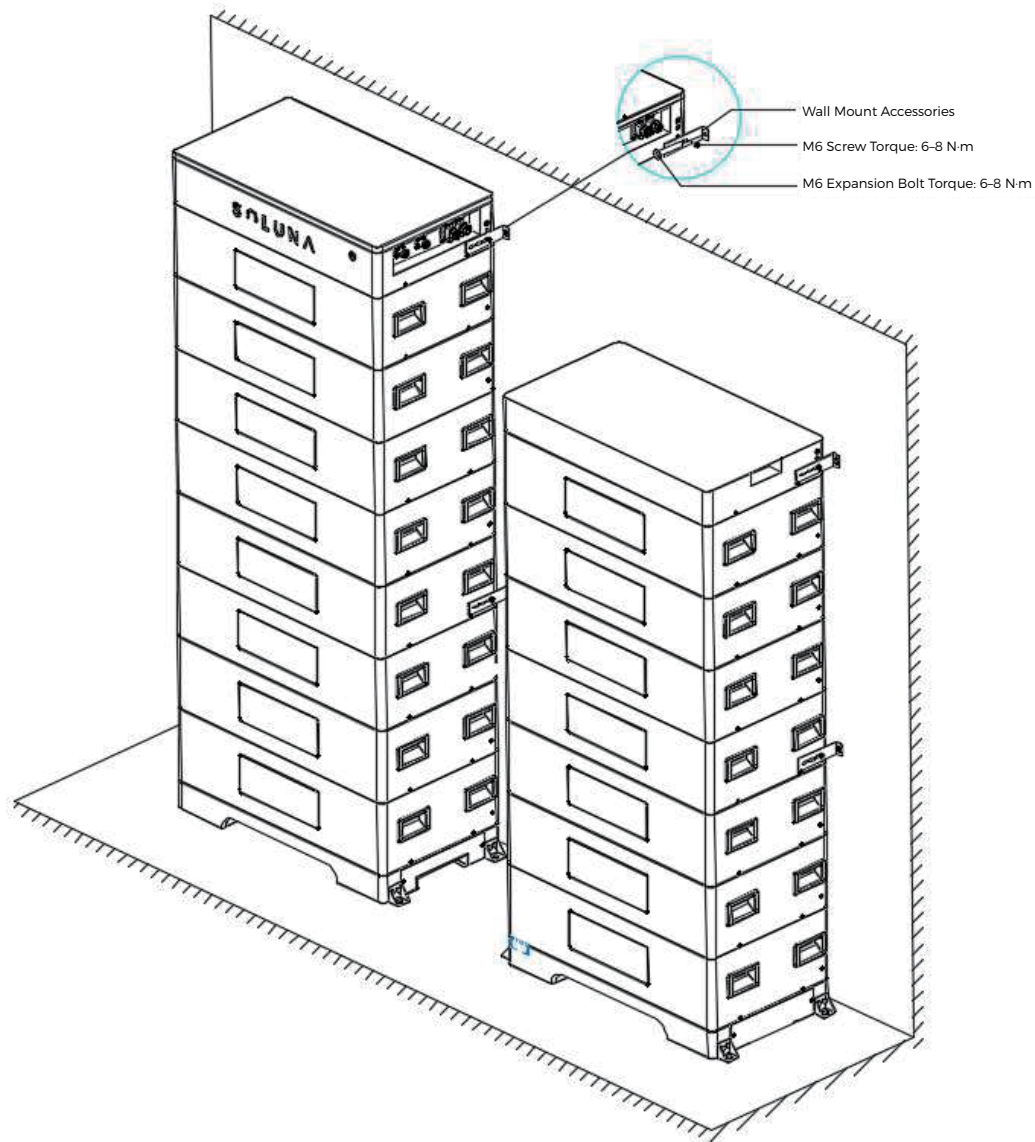

7.5 Install The Battery

Step 7:

Pass the cables through the bottom cable duct and connect as shown in the figure: the positive terminal of the first base corresponds to the negative terminal of the second base, and the negative terminal of the first base corresponds to the positive terminal of the second base. Connect the communication cables between the two bases directly.

As shown in the figure, use M3 screws to secure the cable duct and the side covers to the base.

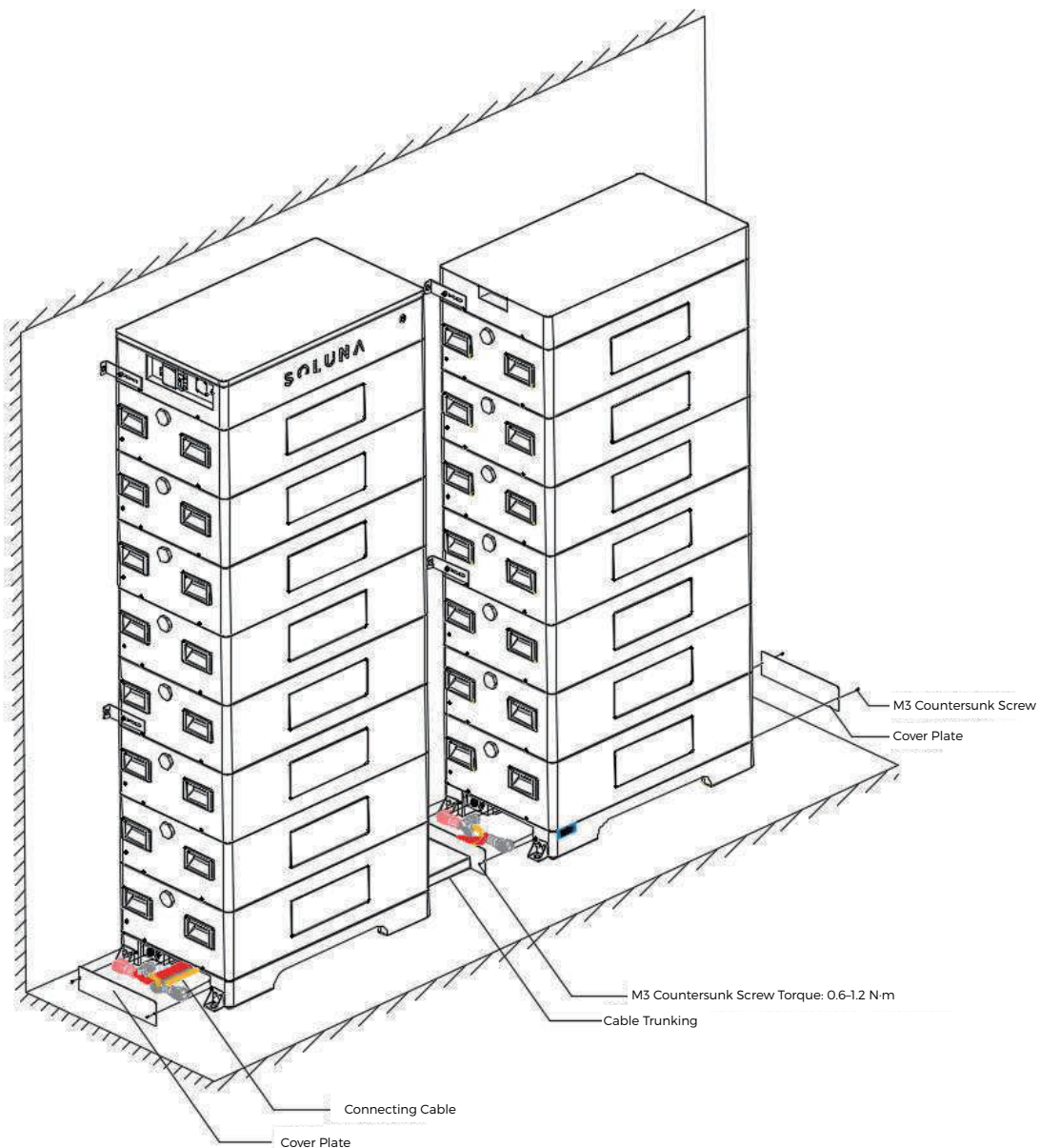

7.5 Install The Battery

Assembly Diagram for ≤8 Battery Modules

Step 1:

Following the operation steps, drill holes on the wall after calculating the positioning dimensions as shown in the figure (N represents the number of modules).

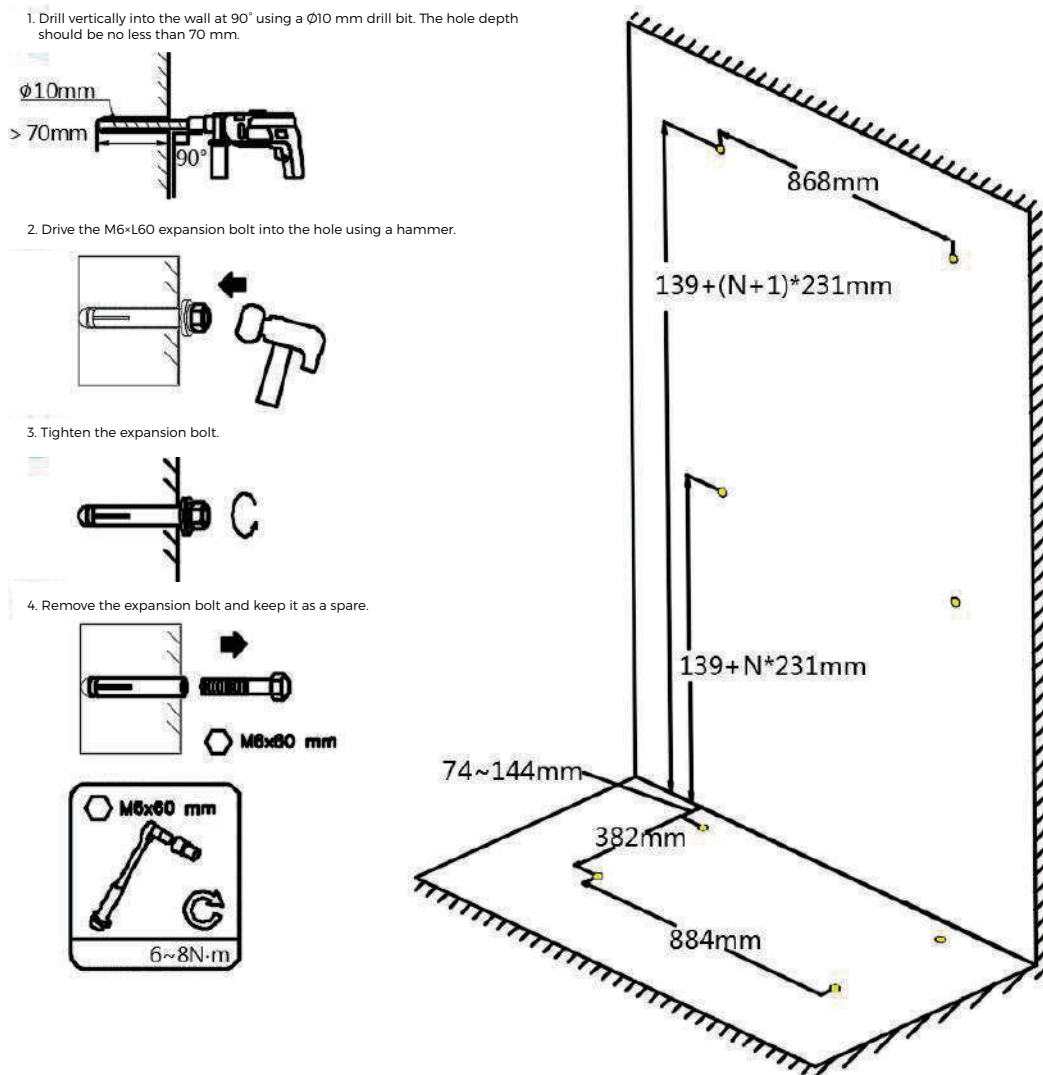

7.5 Install The Battery

Step 2:

For module stacking assembly, refer to the standard for ≥ 8 modules. Open the cover as shown in the figure, insert the corresponding connection cables, and then close and secure the cover.

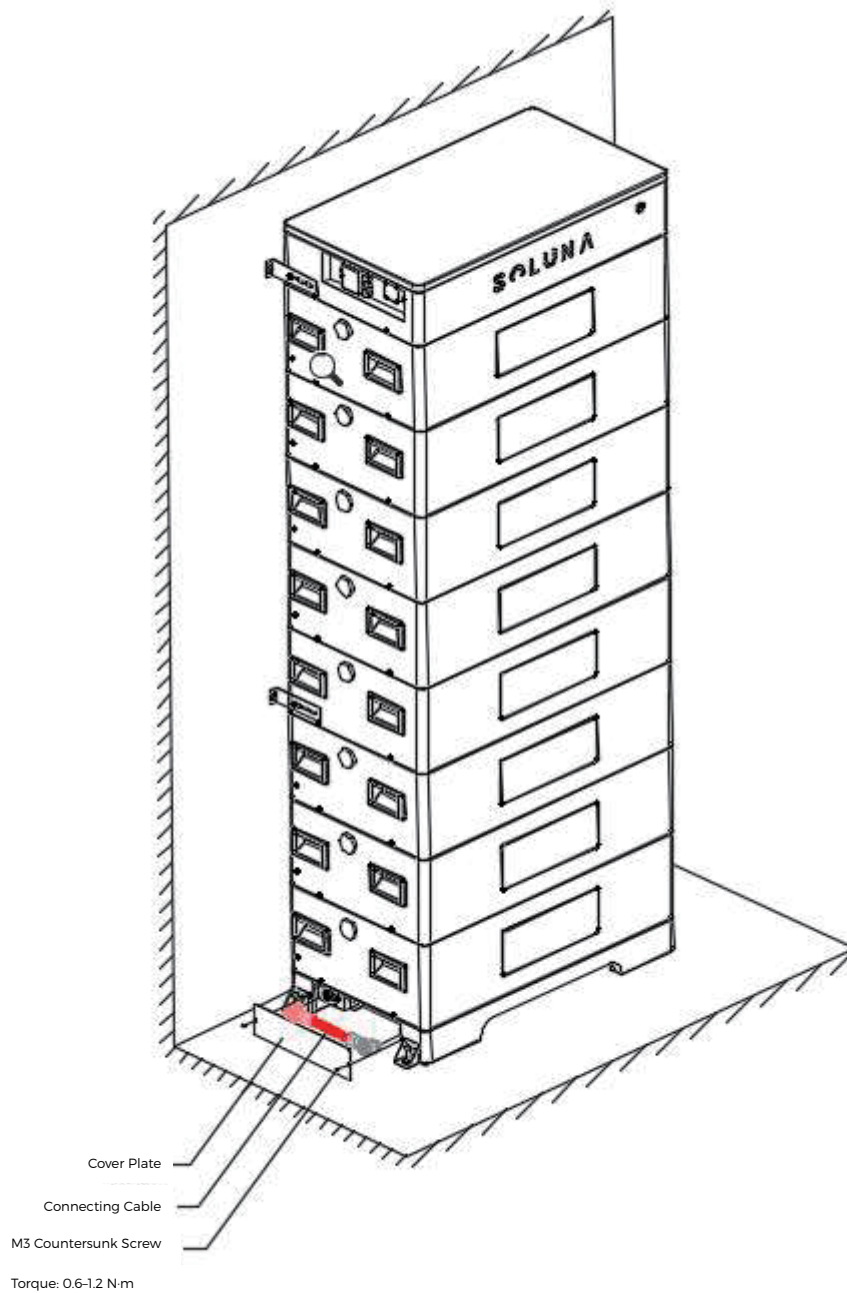

8 Electrical connection

8.1 Connection requirements

- **Safety note:** Power supply to the inverter and battery must be cut off before connection to avoid electric shock.
- **Grounding Instructions:** This product must be connected to a grounded, metallic, permanent wiring system.
- **Note:** Personal protective equipment, such as safety shoes, safety gloves, insulating gloves, etc. must be worn during electrical connection.
- All electrical connections should be made by qualified professionals.
- The cable colors in this document are for reference only. The cable specifications must comply with local laws and regulations.
- Equipment damage caused by incorrect wiring is not covered by the equipment warranty.

8.2 Connection steps

- **Step 1**
Crimp the manufacturer-provided terminals onto both ends of the charging wires. Then connect the red wire to the positive terminal of the battery and the positive terminal of the inverter; connect the black wire to the negative terminal of the battery and the negative terminal of the inverter.
- **Step 2**
Connect the communication cable to the BMS port of the inverter and the CAN1 port of the battery.

Emergency Stop Function: Users can choose to add a switch here to control the battery output. “Normally open” means normal operation, while “shorted” means disconnected.

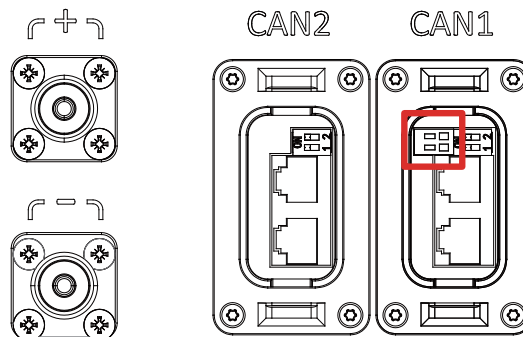

8.3 Wi-Fi module connection

8 Electrical connection

8.3.1 Single unit connection

- Step 1

Install the bracket of the WIFI module onto the BMU, and then fix the WIFI module onto the bracket.

- Step 2

Connect the communication cable of the WIFI module to the WIFI module and the CAN2 port of the battery.

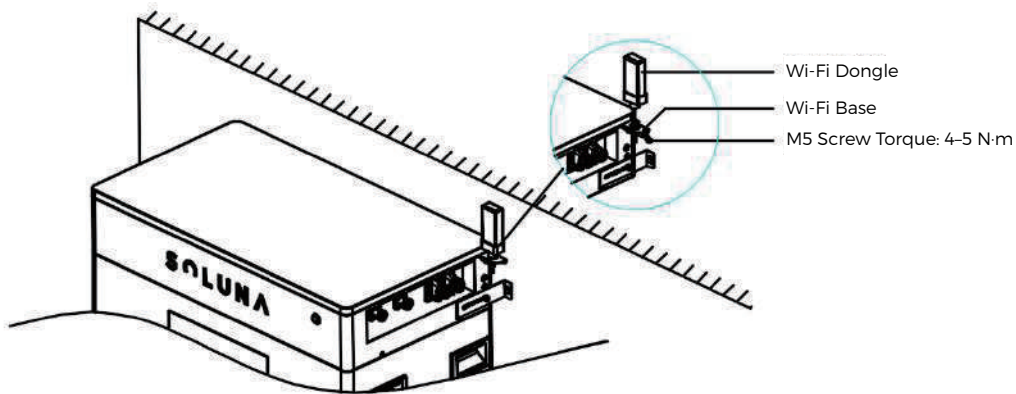

8.3.2 Parallel unit connection

User only need to install 1 unit Wi-Fi module on the HV parallel box, Please find the following position of Wi-Fi module for details.

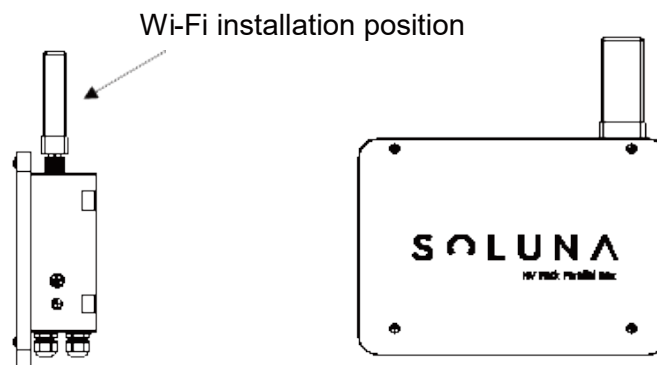

Remark:

1) User can find the user manual of Wi-Fi module in the Wi-Fi packing box.

8 Electrical connection

8.4 Electrical system connection diagram

Standalone

- Communication cable
- Battery positive pole
- Battery negative pole

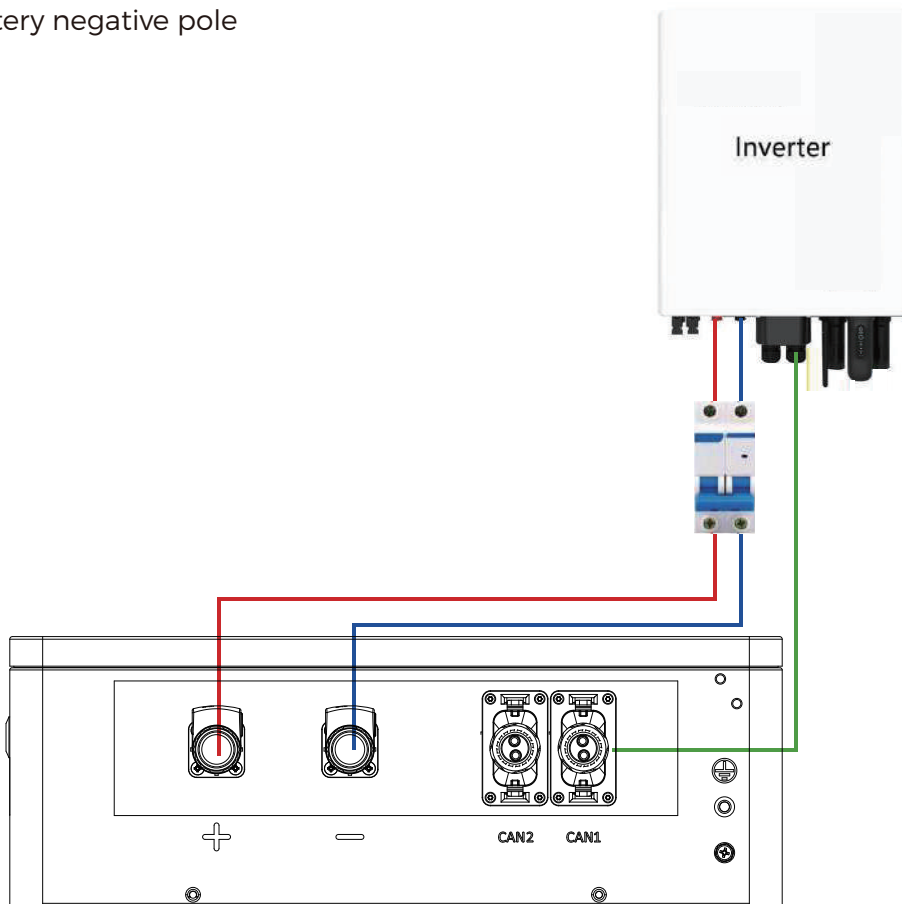

8 Electrical connection

8.4 Electrical system connection diagram

Multiple Clusters

- Communication cable
- Battery positive pole
- Battery negative pole

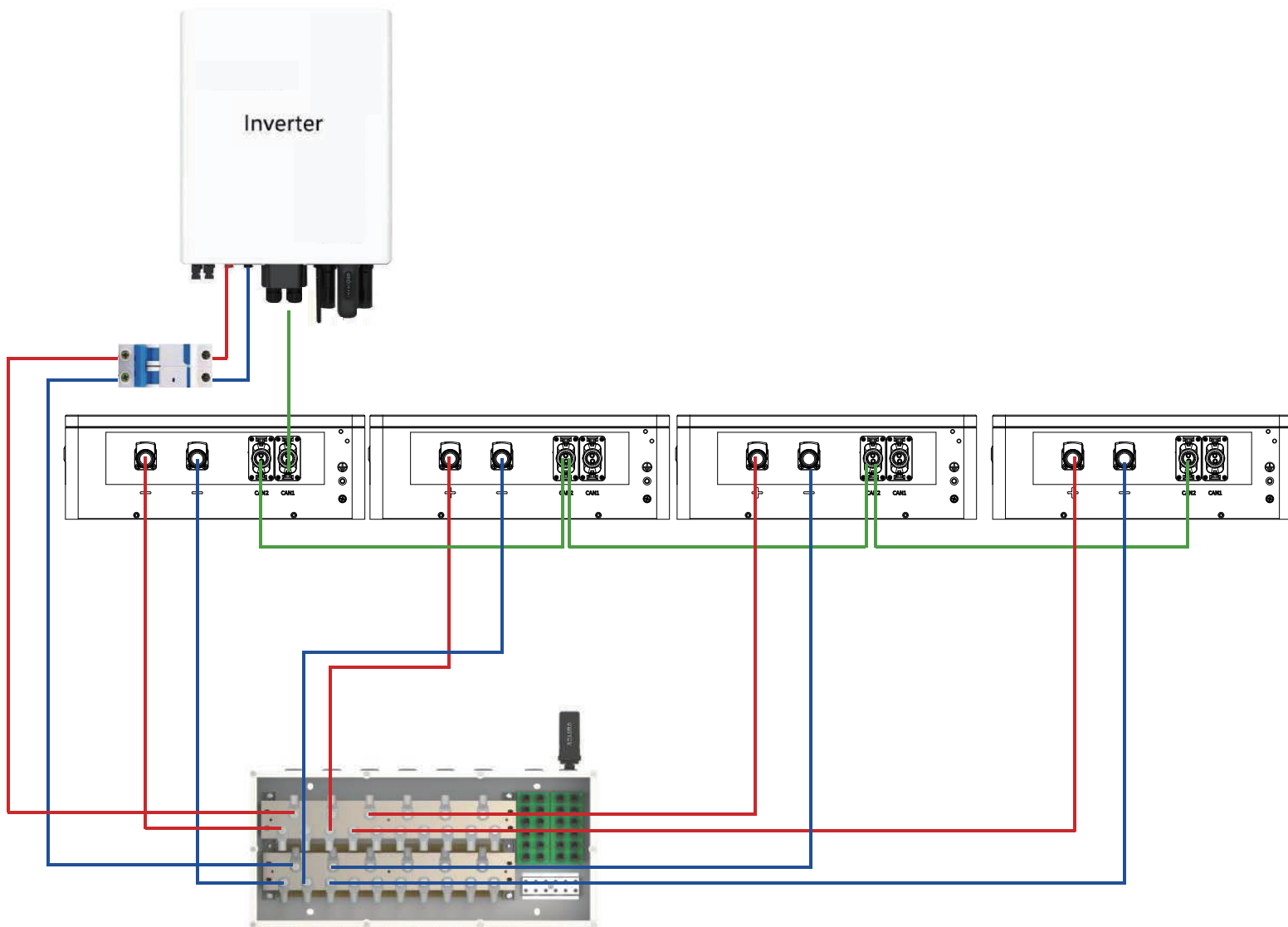

2 units in parallel:
Turn the dial switches of Can2 for both batteries to ON and the dial switch of Can1 to position 1.2



4 units in parallel:
Set the CAN2 DIP switches of the first and last batteries to ON.
Set the CAN2 DIP switches of the middle batteries to positions 1 and 2.
Keep the CAN1 DIP switches unchanged.

NOTE: Parallel operation is permitted ****only when the batteries are of the same model and have the same number of modules****.

9 Operation instructions

9.1 Check before starting up

- Ensure the equipment is firmly installed, accessible for operation and maintenance, with adequate ventilation.
- Verify that ground, power, communication, and AC cables are properly and securely connected.
- Ensure cables are neatly bundled and undamaged.
- All switches should be OFF before power-up.

Warnings:

- Do not reverse polarity or short-circuit battery terminals.
- Do not misconnect BMS communication cables.
- Damage due to incorrect wiring is not covered under warranty..

9.2 Startup



Check Rotary switch:

Verify that the Rotary switch on the left side of the BMU matches the number of stacked modules (e.g., set to 5 for 5 modules).

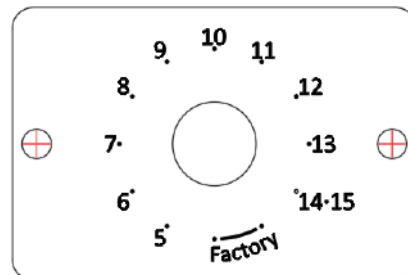







- **Step 1: Turn ON Breaker**
Wait about 1 minute for the battery status LED to illuminate.
- **Step 2: Power ON Inverter**
Enable inverter power (PV or grid), allowing the inverter to start.
- **Step 3: Select Battery Protocol**
Choose the correct battery communication protocol on the inverter to ensure proper communication.
- **Step 4: Test Charge/Discharge**
Verify that the battery can charge and discharge normally.

Notice:

- Soluna HV Ultra Series must communicate normally with the inverter to operate.
- In pure off-grid mode (no PV or grid), press and hold the black start button to activate the system.

10 status indicator light introduction

Please find the following table for details.

Number	Color	Description
1	 Red	1. Battery is on black start mode. To active battery black start mode, please press the black start button and hold for 10 seconds. Battery can power the inverter and active the communication with inverter if there is no power grid or solar panels. 2. BMS hardware anomaly.
2	 Purple	Battery has lost communication with inverter for over 5 minutes.
3	 Yellow	Battery is on protection model. The battery reached to the 3rd level protection alarm such as over voltage, under voltage, over temperature, low temperature, etc.
4	 White	Battery is on working model. If there are more than one battery in parallel connection, it means this battery is the master battery on working model.
5	 Green	Battery is on working model as a slave battery in parallel connection.
6	 Blue	BMS hardware anomaly

11 Maintenance and troubleshooting

11.1 Maintenance

- It is recommended that the battery system needs to be recharged every 6 months from the time it leaves the factory.
- When the system is not used for a long time, it is necessary to disconnect the battery output to avoid battery exhaustion.
- During system operation, professionals should regularly check the system for abnormalities and faults. If any problems are found, please deal with them in time. Otherwise the battery system will be permanently damaged.
- Professionals should regularly clean the surface and interior of the system (with all power disconnected)
- During the storage period, professionals should regularly check the battery system for abnormalities, if any problems are found, please deal with it in time.

11.2 Troubleshooting

Faults	Cause	Maintenance method	Solution
LED light is purple	Compatible inverter firmware is not the latest reversion	Check the inverter APP or LCD/LED for firmware reversion	Update inverter's firmware
	Battery firmware is not the latest reversion	Check the Soluna smart energy cloud for firmware reversion	Update battery's firmware
	Installer didn't choose Soluna battery correctly on inverter APP or LCD/LED	Check if the selection of battery is correct or not	Reselect Soluna battery on inverter
	Communication cable is loose or not correct	Check the communication cable status	Replug or change the communication cable
	Inverter hardware fault	Change another inverter to try	Contact with inverter manufacture
	Battery hardware fault	If you checked all the items above and still can't target the reason, please contact with Soluna. Or change the battery	Contact with Soluna for further action

11 Maintenance and troubleshooting

Battery can't be charged or discharged	Inverter setting incorrect such as disable the charging or discharging, and time setting, etc.	Check the inverter setting	Change the inverter setting
	Inverter can't read Soluna battery type correctly.	Check the battery type of product and product name shown in inverter side.	Contact with Inverter manufacture or Soluna for further action.
	Inverter hardware fault.	Change another inverter to try.	Contact with Inverter manufacture.
	Battery hardware fault.	Please change another battery to try.	Contact with Soluna for further action.
LED light is off or yellow	Off-grid installation, battery can't be charged for over 2 weeks due to no production of PV system(raining season, snow season, or PV system fault).	Check the battery voltage.	Contact with Soluna for further action.
	Customer didn't turn off the battery for over 2 weeks in the scenario such as:A. Installation is not finished. B. System failure, not running.		
	The battery was stocked for over 2 years without charging.		
Battery firmware is not updated to latest	The battery firmware is continuously being optimized and updated	Check the Soluna smart energy cloud for battery firmware reversion.	Updating the battery firmware to the latest.
Master battery is white, but not all slaver battery are green	Battery communication cable is loose or not correct.	Check the communication cable status.	Replug or change the communication cable.
	Battery power cable is loose, or not correct connected.	Check the battery power cable.	Fasten the power cable.
	Communication terminal resistor is not dailed or not dailed correctly.	Check the parallel box for the resistor dailling.	Dail the terminal resistor according to manual or SOP.

11 Maintenance and troubleshooting

	Battery firmware is not the latest.	Check the Soluna smart energy cloud for battery firmware reversion.	Upgrade the firmware to the latest.
WIFI stick failed to configure the network	The Wifi network is not compatible	Check the ender user network type	Please choose only 2.4G wifi mode
	Connecting fail	APP will remind	Please read the SOP of wifi setting up
	System establish failed due to S/N invalid.	APP will remind	Contact with Soluna for further action
LED light is yellow	Battery reach to 3rd level alarm such as battery over voltage.	1.Check the inverter LCD/LED or APP for the battery alarm information. 2.Check the Soluna smart energy cloud for battery alarm information.	Battery will shut down, please contact with Soluna for further action.

Notice:

Damage to the battery system due to under voltages

- Charge the over-discharged system within seven days when the temperature is above 25°C.
- Charge the over-discharged system within fifteen days when the temperature is below 25°C.
- If the battery system doesn't start up, please contact Soluna local after-sales service within 48 hours. Otherwise, the battery could be permanently damaged.

12 Depth of Discharge(DOD) Setting for Inverter

To make sure the battery working smoothly, we recommend the DOD setting of inverter as follows.

On-Grid DOD: 80%

Off-Grid DOD: 70%

In energy storage systems, reducing the depth of discharge (DOD) of lithium batteries is aimed at improving system economics, extending battery life, enhancing safety, and optimizing performance. Below are the specific reasons:

1. Extending Battery Life

- The cycle life of lithium batteries is closely related to the depth of discharge. Deep discharge (e.g., 80%-100% DOD) accelerates battery aging, leading to faster capacity degradation.
- Reducing DOD (e.g., controlling it between 20%-80%) can significantly extend the battery's cycle life, thereby lowering long-term maintenance and replacement costs for the energy storage system.

2. Improving System Economics

- Batteries account for a significant portion of the cost in energy storage systems. Extending battery life means reducing the frequency of battery replacements and lowering the total lifecycle cost.
- Although reducing DOD decreases the available energy per cycle, the overall energy throughput (total charge-discharge capacity) may increase by extending battery life, there by improving economic efficiency.

3. Enhancing Safety

- Deep discharge increases the risk of over-discharge, causing the battery voltage to drop too low, which may lead to irreversible chemical damage (e.g., dissolution of the copper current collector in the anode).
- Reducing DOD can prevent over-discharge, minimize safety risks such as thermal runaway, and ensure stable operation of the energy storage system.

13 Register on the Website after Installation

After completing the installation of the battery system and confirming that it is operating normally, please log in to the Soluna official website to register your product installation and usage details. This registration is required for the product warranty to take effect. Follow the on-screen instructions on the website to complete the registration process.

<https://soluna.co> → SUPPORT & SERVICE → Warranty registration

If you have any questions, feedback, or need assistance, please feel free to reach out to us. We are here to help!

Soluna (Shanghai) Co.,Ltd

Add: No.3492 Jinqian Road, Shanghai, China 201406

Tel: +86-21-57475835

Email: sales@solunabattery.com

Web: www.solunabattery.com

Social media: <https://www.linkedin.com/company/solunabattery>