

User Manual
Lithium Battery System
Soluna HV Ultra Series
A.0

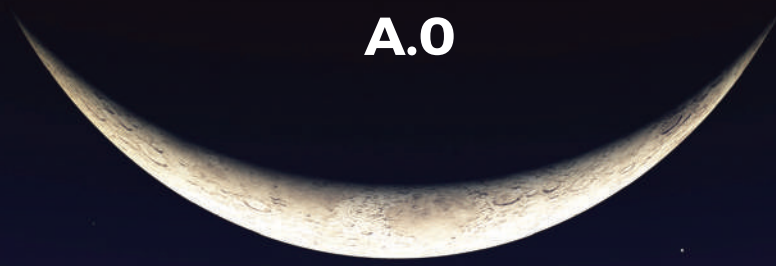

About this Specification

This user manual provides detailed instructions for the installation, operation, and maintenance of the Soluna HV Ultra Series high-voltage lithium battery system.

This product is a high-voltage energy storage system and must be installed, commissioned, and maintained only by qualified and authorized personnel in accordance with local laws, regulations, and applicable standards.

Please read this manual carefully and completely before installing or operating the system. Failure to follow the instructions and safety guidelines in this manual may result in personal injury, equipment damage, or system malfunction.

The information contained in this document is accurate at the time of publication. Soluna (Shanghai) Co., Ltd. reserves the right to modify product design, specifications, and documentation without prior notice. Illustrations in this manual are for reference purposes only and may differ from the actual product.

© Soluna (Shanghai) Co., Ltd. All rights reserved.

1. Introduction.....	05
2. Product Overview.....	06
2.1 Features.....	06
2.2 Applications.....	06
3. Safety Information.....	07
3.1 Warning Sign.....	07
3.2 Safety Instructions.....	08
3.2.1 Risks of Explosion.....	08
3.2.2 Risks of fire	08
3.2.3 Risks of electric shock.....	08
3.2.4 Risks of damage to the battery pack	08
3.3 Battery handling guide.....	09
3.4 Response to emergency situations.....	09
3.4.1 Leaking batteries	09
3.4.2 Inhalation.....	09
3.4.3 Eye contact.....	09
3.4.4 Skin contact.....	09
3.4.5 Ingestion.....	10
3.4.6 Fire.....	10
3.4.7 Wet batteries.....	10
3.4.8 Damaged batteries	11
3.5 Qualified installers Requirements.....	11
4. Appearance.....	12
5. Technical Specifications	14
6. Connection Port	16
7. COM Communication Interface Definition	18
8. LED Lights Definition.....	27
9. Operation instructions.....	31
9.1 Check before starting up.....	31
9.2 Startup	31
10. Status indicator light introduction.....	32
11. Maintenance and troubleshooting.....	33
11.1 Maintenance	33
11.2 Troubleshooting	33

Contents

12. Depth of Discharge (DOD) Setting for inverter.....	36
13. Register on the Website after Installation	37
14. Contact us.....	38

The Soluna HV Ultra Series is a high-voltage lithium iron phosphate (LFP) battery system designed for reliable and safe energy storage applications.

The system is equipped with an advanced Battery Management System (BMS) and supports CAN and RS485 communication, enabling seamless integration with compatible inverters and monitoring platforms. Comprehensive protection functions are built in, including over-voltage, under-voltage, over-current, over-temperature, and under-temperature protection, ensuring safe and stable operation under various conditions.

With high energy density, long cycle life, and robust system reliability, the Soluna HV Ultra Series is suitable for backup power, microgrid solutions, and small commercial and industrial energy storage applications.

2.1 Features













- **Excellent Safety Performance**
Ensures the highest level of safety under various conditions.
- **Long Cycle Life**
Designed for extended usage without significant performance degradation.
- **Support for CAN-communication**
Provides support for CAN-based communication between devices.
- **High energy density**
Features high energy density for efficient power storage.
- **Excellent battery management system**
Equipped with an excellent battery management system (BMS) for safety and efficiency.
- **Number of expandable battery module, at least 3, up to 11**
Supports 3 to 11 expandable battery modules.
- **Wi-Fi monitor**
Wi-Fi monitoring supported.
- **Active balancing function, manage the consistency of batteries more efficiently**
Active balancing function for efficient battery consistency management.
- **Built-in fire extinguishing device**
Built-in fire extinguishing device for enhanced safety.
- **Small size and light weight, easy installation and maintenance of standard module**
Compact and lightweight design for easy installation and maintenance.

2.2 Application

- Back-up power
- Micro-grid
- Home Energy Storage system

3.1 Warning Signs

Warning signs are essential indicators designed to alert you to conditions that could result in severe injury or significant damage to the device. They serve as critical reminders to exercise caution and take necessary precautions to prevent hazardous situations. The table below outlines the warning signs used in this manual and their meanings:

Sign	Description
	High Voltage Warning: This battery pack operates at high voltage, which can cause severe injury due to electric shock.
	Correct Polarity: Ensure the battery polarity is correctly connected.
	Fire Safety: Keep the battery pack away from open flames or ignition sources.
	Child Safety: Store the battery pack out of reach of children.
	Installation Manual: Thoroughly read the manual before installing and operating the battery pack.
	Heavy Weight Warning: The battery pack is heavy, and improper handling may result in severe injury. Utilize proper lifting techniques.
	Electrolyte Leakage: The battery pack may leak corrosive electrolyte. Handle with care and adhere to appropriate safety procedures.
	Explosion Risk: The battery pack may explode under certain conditions.
	Disposal Instructions: Do not dispose of the battery pack with household waste at the end of its working life. Follow local regulations for disposal.
	Compliance Requirement: Failure to follow the provided requirements and guidelines may lead to physical injury or damage to the device.
	Do not short circuit.
	Grounding conductor This symbol indicates the position for connecting a grounding conductor.

3.2 Safety Instructions

For safety reasons, it is crucial that installers thoroughly familiarize themselves with the contents of this manual and all associated warnings prior to commencing the installation.



General Safety Precautions

Failure to adhere to the precautions outlined in this section can result in serious injury or property damage. Please observe the following safety guidelines:

3.2.1 Risks of Explosion

- Avoid subjecting the battery pack to strong impacts.
- Do not crush or puncture the battery pack.
- Never dispose of the battery pack in a fire.

3.2.2 Risks of Fire

- Do not expose the battery pack to temperatures exceeding 60°C.
- Keep the battery pack away from heat sources, such as fireplaces.
- Avoid exposing the battery pack to direct sunlight.
- Ensure the battery connectors do not come into contact with conductive objects like wires.

3.2.3 Risks of Electric Shock

- Refrain from disassembling the battery pack.
- Do not touch the battery pack with wet hands.
- Keep the battery pack away from moisture or liquids
- Ensure the battery pack is kept away from children and animals.

3.2.4 Risks of Damage to the Battery Pack

- Do not allow the battery pack to come in contact with liquids.
- Do not subject the battery pack to high pressures.
- Do not place any objects on top of the battery pack.

3.3 Battery Handling Guide

- Use the battery pack only as directed.
- Do not use the battery pack if it appears defective, cracked, broken, or fails to operate correctly.
- Do not attempt to open, disassemble, repair, tamper with, or modify the battery pack as it is not user serviceable.
- Handle the battery pack with care during transportation to avoid damage.
- Avoid impacting, pulling, dragging, or stepping on the battery pack.

3.4 Response to Emergency Situations

The Soluna HV Ultra series battery pack comprises multiple battery modules designed with protective measures to reduce risks resulting from abnormal conditions. However, as with all high-voltage energy storage systems, potential hazards may still exist if the product is improperly handled or installed.

3.4.1 Leaking Batteries

If the battery pack leaks electrolyte, avoid contact with the leaking liquid or gas. The electrolyte is corrosive and contact may cause skin irritation and chemical burns. If someone is exposed to the leaked substance, do these actions:

3.4.2 Inhalation

If electrolyte vapors are inhaled, move the affected person to fresh air immediately. Seek medical attention if discomfort persists.

3.4.3 Eye Contact

- Rinse eyes with flowing water for at least 15 minutes.
- Seek medical attention immediately.

3.4.4 Skin Contact

- Wash the affected area thoroughly with soap and water.
- Seek medical attention immediately.

3.4.5 Ingestion

- Do NOT induce vomiting.
- Rinse mouth with water if the person is conscious.
- Seek medical attention immediately.

3.4.6 Fire Response Procedures

In the event of a fire, always have an ABC or carbon dioxide extinguisher on hand.



The battery pack may ignite if heated above 150 °C. If a fire occurs where the battery pack is installed, follow these steps:

- **Extinguish Early**

Attempt to extinguish the fire before the battery pack ignites.

- **Safe Relocation**

If extinguishing is not possible but time allows, move the battery pack to a safe area before it catches fire.

- **Evacuate**

If the battery pack has already caught fire, do not attempt to extinguish it. Evacuate the area immediately.



Caution: If the battery catches fire, it will emit noxious and poisonous gases. Do not approach the fire.

3.4.7 Wet Batteries

If the battery pack becomes wet or submerged in water, do not attempt to access it. Contact Soluna or your distributor for technical assistance immediately.

3.4.8 Damaged Batteries

Damaged batteries may leak electrolyte or produce flammable gases. If battery damage is suspected, contact Soluna immediately for further guidance.

Damaged batteries are hazardous and must not be used. Handle them with extreme caution to avoid injury or property damage.



Leakage and Flammability: Damaged batteries may leak electrolyte or produce flammable gas. If you suspect such damage, contact Soluna for advice and information immediately.

3.5 Qualified Installers

This manual, as well as the installation, operation, and maintenance procedures described herein, is intended for use by qualified professionals only.

- **Functional Knowledge**

Understanding of the principles and operation of on-grid and off-grid energy storage systems.

- **Risk Awareness**

Awareness of the hazards associated with installing and operating electrical equipment, and knowledge of appropriate risk mitigation methods.

- **Installation Proficiency**

Proven experience in the installation of electrical and energy storage equipment.

- **Adherence to Guidelines**

Knowledge of and compliance with this manual, including all safety instructions and applicable standards.

- **Battery Maintenance**

Only authorized personnel may perform maintenance. The battery must be powered off before maintenance. Voltage, SOC, and cables should be periodically inspected. It is recommended to perform full charging for balancing maintenance every three months.

- **Installation Environment Requirements**

The battery system must be installed in an environment free from flammable, explosive, or corrosive materials. Keep the system out of reach of children and away from high temperatures.

Ensure proper ventilation and avoid strong electromagnetic interference. The system should be installed in a sheltered, well-ventilated location within the specified temperature and humidity range and at an altitude below 2,000 meters.

4.1 Soluna Ultra System introduction

The Soluna Ultra System includes Soluna HV Ultra BMU and Soluna HV 7.5K Ultra Module

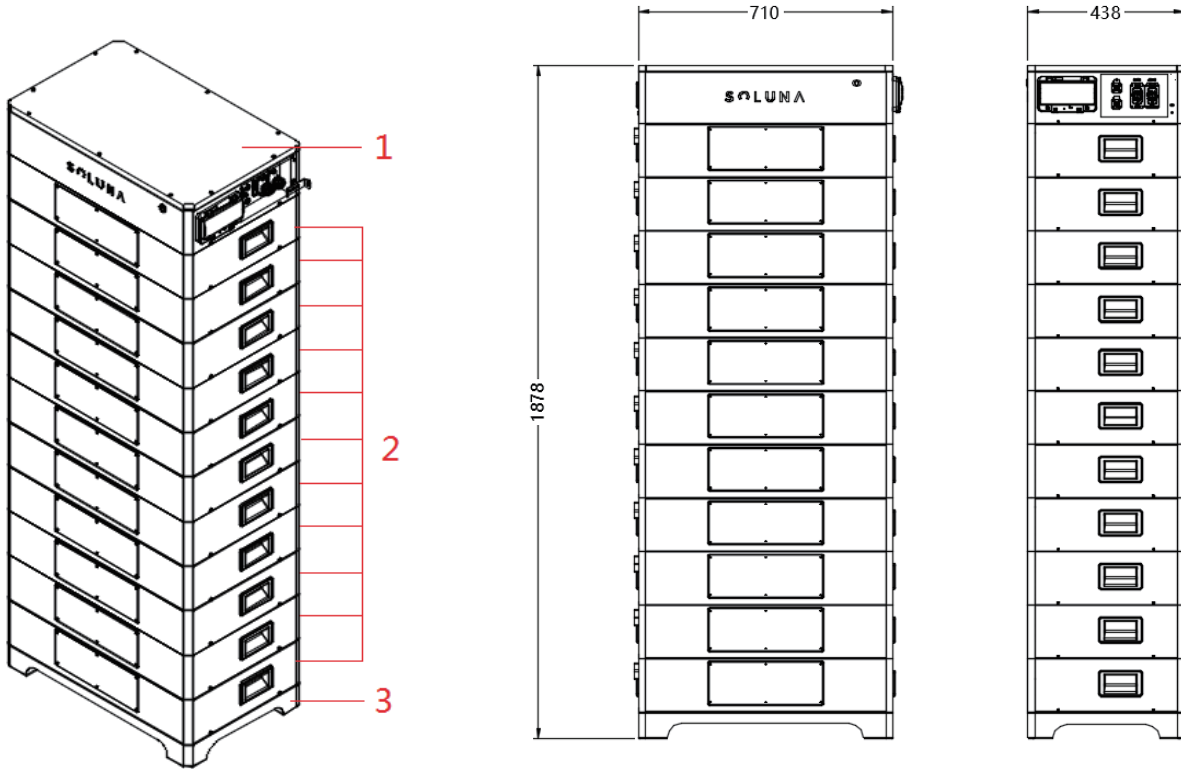

Width	710	mm
Depth	438	mm
Height	1878	mm

Number	Name	Description
1	Soluna HV Ultra BMU	The high-voltage box
2	Soluna HV 7.5K Ultra Module	76.8VDC/100Ah
3	Base	Support and mounting assembly

4 Appearance

4.2 Soluna HV 7.5K Ultra Module introduction

Note: Please select the appropriate number of battery modules and BMUs according to your actual requirements when placing an order.

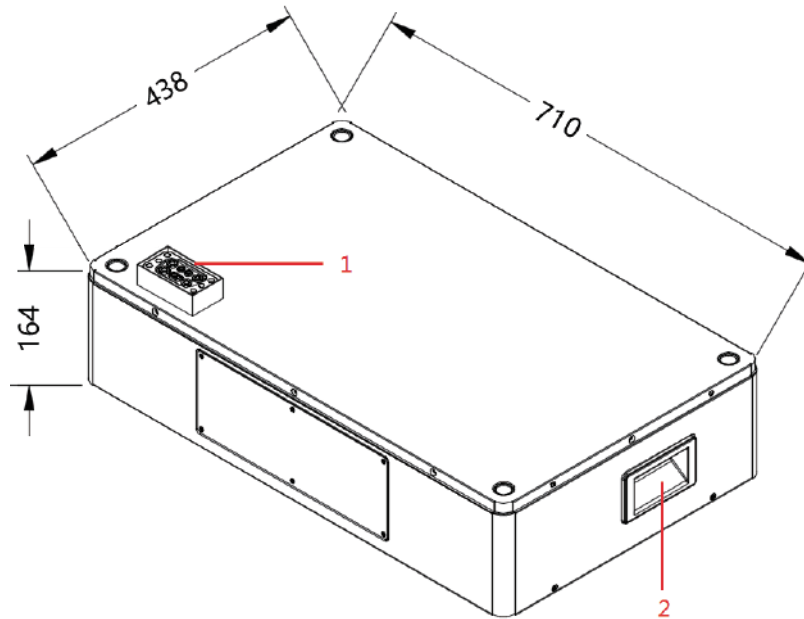

Width	710	mm
Depth	438	mm
Height	164	mm
Weight	62	kg

Number	Name	Description
1	Stacked connector socket	Battery module series connection port
2	Recessed handle	Built-in handle for convenient transport and installation

4.2 Soluna Ultra BMU introduction

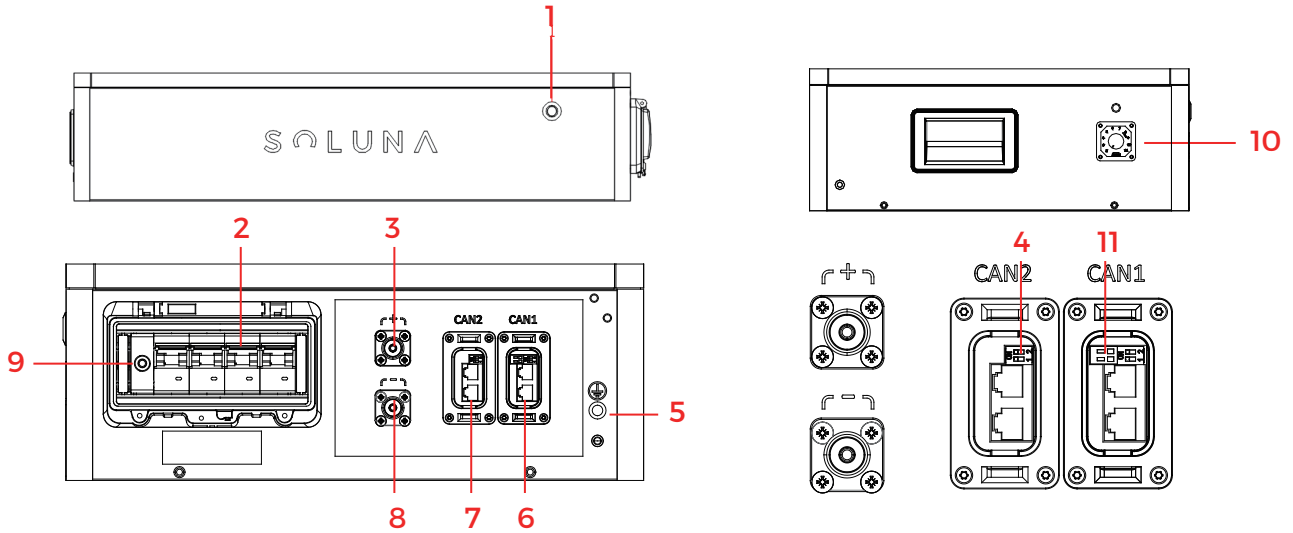

Number	Name	Description
1	LED light	Status indicator light
2	Breaker	For controlling the output and cutting off the battery voltage
3	The positive port of the battery	Output positive of battery module
4	DIP switch	For parallel terminal resistors
5	PE	Ground point
6	CAN1 port	For communicate with the inverter
7	CAN2 port	For communicate between batteries
8	The negative port of the battery	Output negative of battery module
9	Black Start button	Press and hold for about 10 seconds to output the battery voltage
10	Rotary switch	For adjust battery start and under-voltage protection
11	Emergency stop terminal	For emergency control to cut off battery output

5 Technical parameters

Model	HV Ultra 23K	HV Ultra 30K	HV Ultra 38K	HV Ultra 46K
Physical characteristics				
Dimensions (W * D * H)	710x438x686	710x438x835	710x438x984	710x438x1133
Weight(kg)	206	268	330	398
Electrical characteristics				
Battery type	LFP			
Total Energy Capacity(kWh)	23.04	30.72	38.4	46.08
Usable Energy Capacity(kWh)	20.74	27.65	34.56	41.47
Battery Capacity (Nominal)(Ah)	100			
Voltage Range(Usable)(V)	201.6~252	268.8~336	336~420	403.2~504
Nominal Voltage(V)	230.4	307.2	384.0	460.8
Charge/Discharge Power (Nominal)(kW)	11.5	15.4	19.2	23.0
Max.Charge/Discharge Power (kW)	11.5/11.5	15.4/15.4	19.2/19.2	23.0/23.0
Charge/Discharge Current (Nominal)(A)	50A / 50A			
Charge/Discharge Current (Max)(A)	50A / 100A			
DOD	90%			
Round-Trip Efficiency	≥96%			
Self discharge @25°C	≤2%			
Cycle life (+0.5C/-0.5C, 25±2°C)	≥8000			
DC Disconnect	Contactor / Fuse			

5 Technical parameters

Model	HV Ultra 53K	HV Ultra 61K	HV Ultra 69K	HV Ultra 76K	HV Ultra 84K
Physical characteristics					
Dimensions (W * D * H)	710x438x1282	710x438x1431	710x438x1580	710x438x1729	710x438x1878
Weight(kg)	460	522	584	646	708
Electrical characteristics					
Battery type	LFP				
Total Energy Capacity(kWh)	53.76	61.44	69.12	76.8	84.48
Usable Energy Capacity(kWh)	48.38	55.30	62.21	69.12	76.03
Battery Capacity (Nominal)(Ah)	100				
Voltage Range(Usable)(V)	470.4~588	537.6~672	604.8~756	672~840	739.2~924
Nominal Voltage(V)	537.6	614.4	691.2	768.0	844.8
Charge/Discharge Power (Nominal)(kW)	26.9	30.7	34.6	38.4	42.2
Max.Charge/Discharge Power (kW)	26.9/26.9	30.7/30.7	34.6/34.6	38.4/38.4	42.2/42.2
Charge/Discharge Current (Nominal)(A)	50A / 50A				
Charge/Discharge Current (Max)(A)	50A / 100A				
DOD	90%				
Round-Trip Efficiency	≥96%				
Self discharge @25°C	≤2%				
Cycle life (+0.5C/-0.5C, 25±2°C)	≥8000				
DC Disconnect	Contactor / Fuse				

5 Technical parameters

Number of batteries that can be connected in parallel	up to 10 units
Monitoring parameters	System Voltage , System Current , Cell Voltage Cell temperature , SOC , Insulation
Operating Conditions	
Condition	Indoor & outdoor conditioned
Operating Temperature (Charge/Discharge)	0~55°C / -20~55°C
Operating Temperature (Recommended)	15~30°C
Storage Temperature	-20~60°C
Humidity	5%~95%
Altitude	Max. 2,000 m
Cooling Strategy	Natural Convection
Reliability & Certification	
Certificates	IEC62477 , IEC62619 , EMC , ROHS
Transportation	UN38.3
Ingress Rating	IP65
Physical Characteristics	
Please refer to SOLUNA WARRANTY CONDITIONS	

6 CAN communication interface definition

Once the cover plate of the Soluna HV Ultra series battery is opened, users can view the connection ports of the battery. Please refer to the images below for detailed visuals.

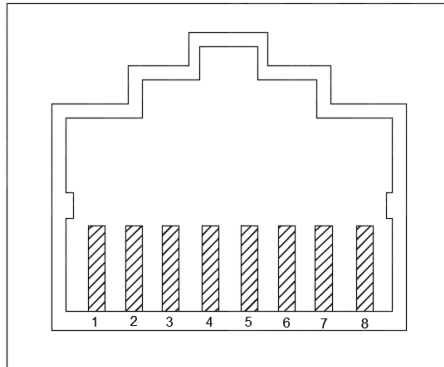

CAN1

1	2	3	4	5	6	7	8
—	—	—	CAN-H	CAN-L	—	—	—

CAN2









1	2	3	4	5	6	7	8
485A	485B	12V+	CAN-H	CAN-L	GND	CAN3H	CAN3L

Remark:

- 1) CAN1 is used for communication with the inverter.
- 2) CAN2 is used for inter-battery communication and BMS data monitoring.

7.1 Packing List

The following table lists the numbers of each item included. If anything is damaged or missing, contact SOLUNA or your distributor.

Item	Name	Description	Qty (pcs)	Photo
1	M4×12 Countersunk Phillips Screw	Used for securely fastening components with a flush surface finish.	6	
2	M4×12 Countersunk Phillips Screw	Used for securely fastening components with a flush surface finish.	4*N	
3	M5×10 Hex Head Phillips Combination Screw	Used for general fastening.	2	
4	M6×10 hex head Phillips combination screw	Used for general fastening.	2	
5	M6×60 expansion bolt	Used for wall or concrete fixing.	6	
6	Wall mounting bracket	Used to securely fix the unit to the wall.	2	
7	Battery parallel communication cable.	Used for connecting multiple units.	1	
8	Charging connector (positive & negative)	Used for charge or discharge.	1+1	

7.2 Installation materials

These installation materials shall be prepared by installers.

- Charging cables
- Network communication cables
- DC breaker

7.3 Installation Location

Intended Use: The Soluna HV Ultra Series is designed and tested for residential installation. Installation in commercial, industrial, or other non-residential environments requires meeting the following location-specific conditions:

- The building is designed to withstand earthquakes.
- The location is far away from the sea, to avoid salt water and humidity.
- The floor is flat and level.
- There are no flammable or explosive materials nearby.
- The ambient temperature is between 15 and 30°C.
- The temperature and humidity stays at a constant level.
- There is minimal dust and dirt in the area.
- There are no corrosive gases present, including ammonia and acid vapor.
- The working temperature range: 0 ~50°C, optimum temperature: 15 ~30°C.



If the ambient temperature is outside the operating range, the battery pack stops operating to protect itself. The optimal temperature range for the battery pack to operate is 15°C to 30°C. Frequent exposure to harsh temperatures may deteriorate the performance and lifetime of the battery pack.

Notice:

Do not place the battery system in direct sun light. it is suggested to build sunshade equipment in cold area the heating system is required.

7.4 Installation Tools Requirements



The following tools are required to install the battery pack:

Remark:

Use properly insulated tools to prevent accidental electric shock or short circuits.

Item	Photo	Name
1		screwdriver bit
2		Wire cutters
3		Wire stripper
4		Tape measure
5		Pistol drill
6		Spirit level
7		Electrical insulating tape
8		Multimeter
9		Marker pen

When handling the battery pack, it is essential to wear the appropriate safety gear to protect against potential hazards, installers must adhere to the relevant requirements of international standards, such as IEC 60364, or comply with domestic legislation.

1		Safety goggles
2		Safety shoes
3		Insulated gloves

7.5 Cable Specifications

In order to standardize the wiring specification of Soluna HV Ultra series battery, the following requirements are required for connecting wires of Soluna HV series battery.

Battery Cable	Communication Cable
It is recommended to use 4AWG (25mm ²) of conductor with double insulation	It is recommended to use standard communication cable with shielding function.

7.6 Install The Battery

NOTE:

Before installation, test each battery module voltage. Voltage should be between 74V and 80V, with a difference of less than 1V between modules.

Test method: Place the module on the base and measure voltage between the marked points on the stacking connector using a multimeter.

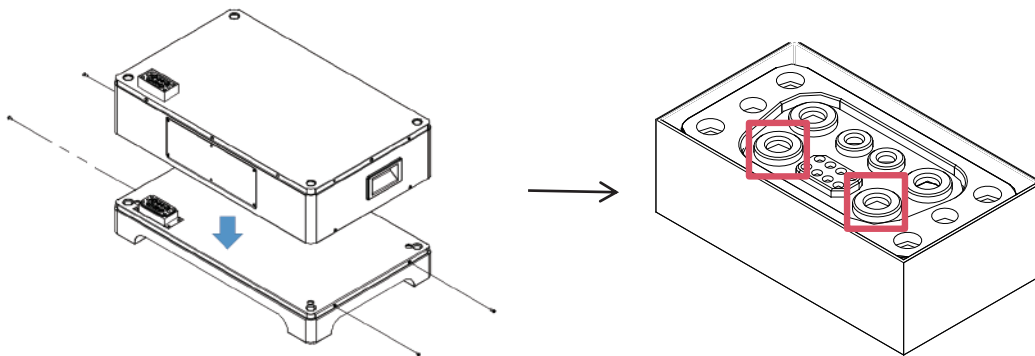

Installation Steps

Step 1: Secure the Base

Drill 4 holes ($\phi 10\text{mm} \times 60\text{mm}$ deep) on a level floor using an impact drill.

Secure the base using M6 \times 60mm expansion bolts.

Adjustable distance between base and wall: 10-30mm.

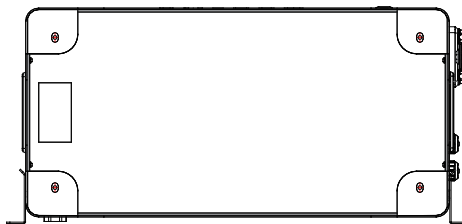

Step 2: Install Wall Mounting Bracket

Drill 2 holes in the wall ($\phi 10\text{mm} \times 60\text{mm}$ deep).

Drilling height formula: $(96.8+195)\text{mm} \times N(96.8+195)\text{mm} \times N$ (where N = number of modules).

Secure bracket with M6 \times 60mm expansion bolts.

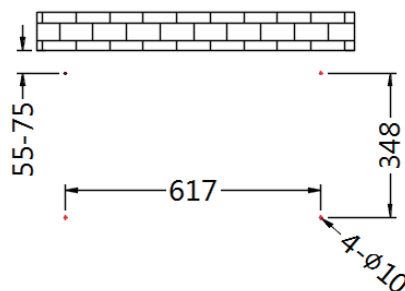

7.6 Install The Battery

Installation Steps

Example: Stack 11 modules and make holes according to the following dimensions

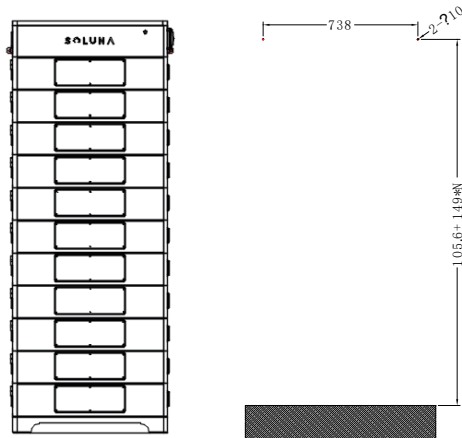

Step 3: Install First Module

When fixing the base, pay attention to its orientation. The marked side should face the wall. Place the module onto the base and secure it with four M4 countersunk screws.

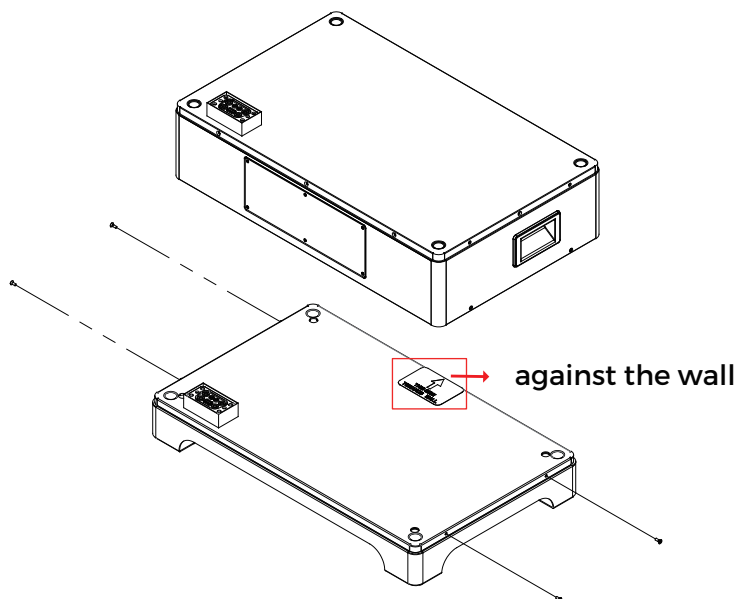

7.6 Install The Battery

Installation Steps

Step 4: Install Subsequent Modules

Align each subsequent module with the previous one.
Secure with M4 screws on both sides.
Repeat until all modules are installed.

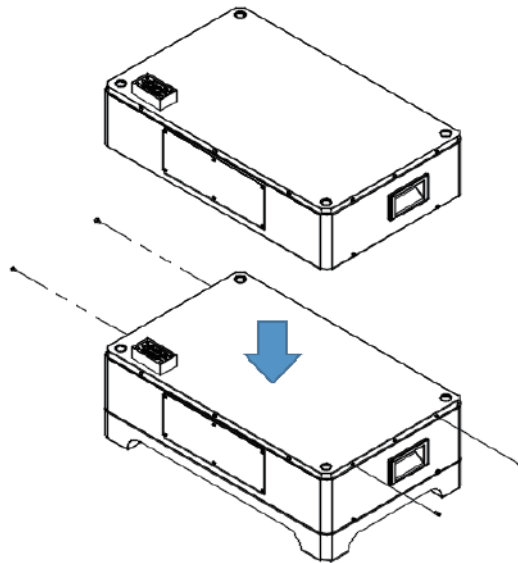

Step 5: Install BMU

Align the BMU with the installed module stack.
Secure with M4 screws on both sides.

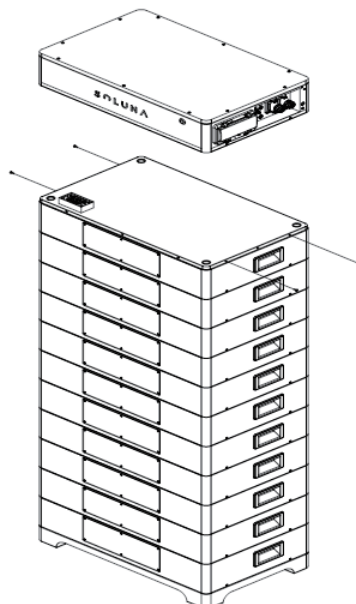

7.6 Install The Battery

Installation Steps

Step 6: Secure BMU to Wall Bracket

Use M6×12mm screws to firmly attach the BMU to the wall bracket.

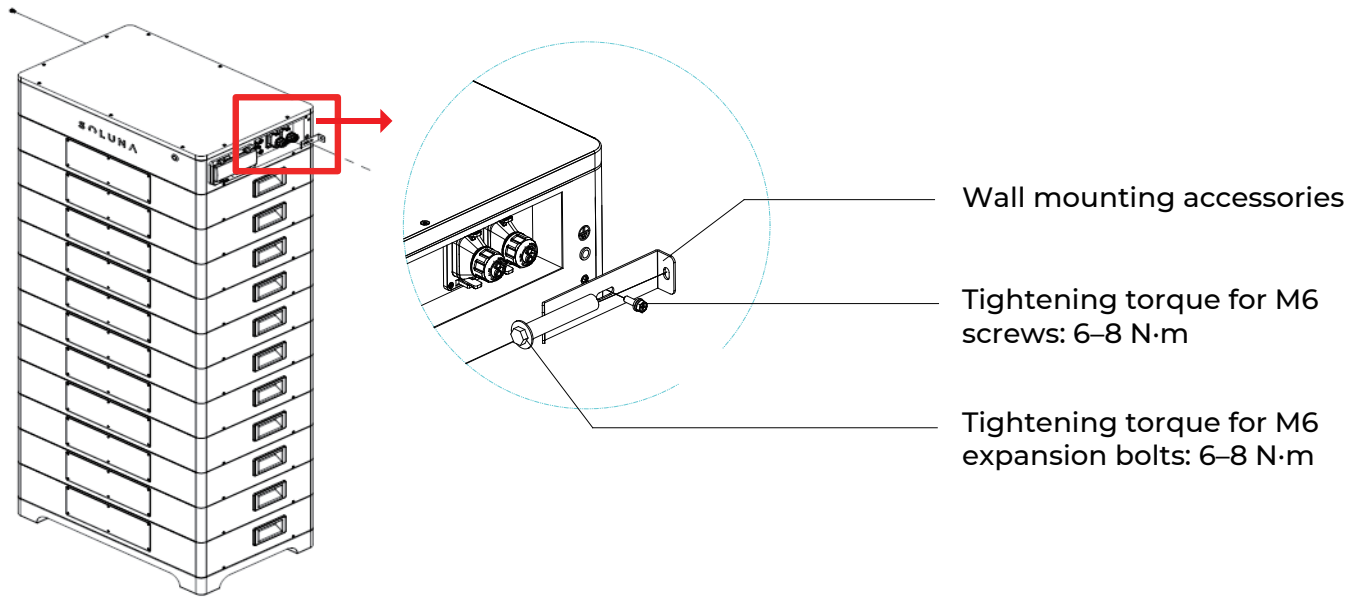

8 Electrical connection

8.1 Connection requirements

- **Safety note:** Disconnect both inverter and battery power before making connections to prevent electric shock.
- **Grounding:** This product must be connected to a grounded, metallic, permanent wiring system.
- **PPE Required:** Wear safety shoes, insulated gloves, and other protective equipment during connection.
- **Professional Installation:** All electrical connections must be performed by qualified personnel.
- **Cable colors are for reference only;** actual specifications must comply with local regulations.
- **Damage caused by incorrect wiring is not covered under warranty.**

8.2 Connection steps

- **Step 1: Connect Power Cables**
 - Crimp provided terminals onto both ends of the charging cables.
 - Connect the red cable to battery positive and inverter positive.
 - Connect the black cable to battery negative and inverter negative.
- **Step 2: Connect Communication Cable**
 - Connect one end to the inverter's BMS port, the other end to the battery's CAN1 port.

Emergency Stop Function: An optional switch can be added here to control battery output. "Normally open" = normal operation; "Shorted" = disconnected.

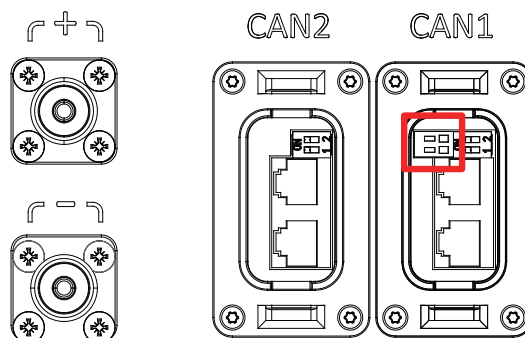

8 Electrical connection

8.3 Wi-Fi module connection

- Step 1
Mount the Wi-Fi module bracket onto the BMU, then fix the module onto the bracket.
- Step 2
Connect the Wi-Fi module communication cable to the battery's CAN2 port.

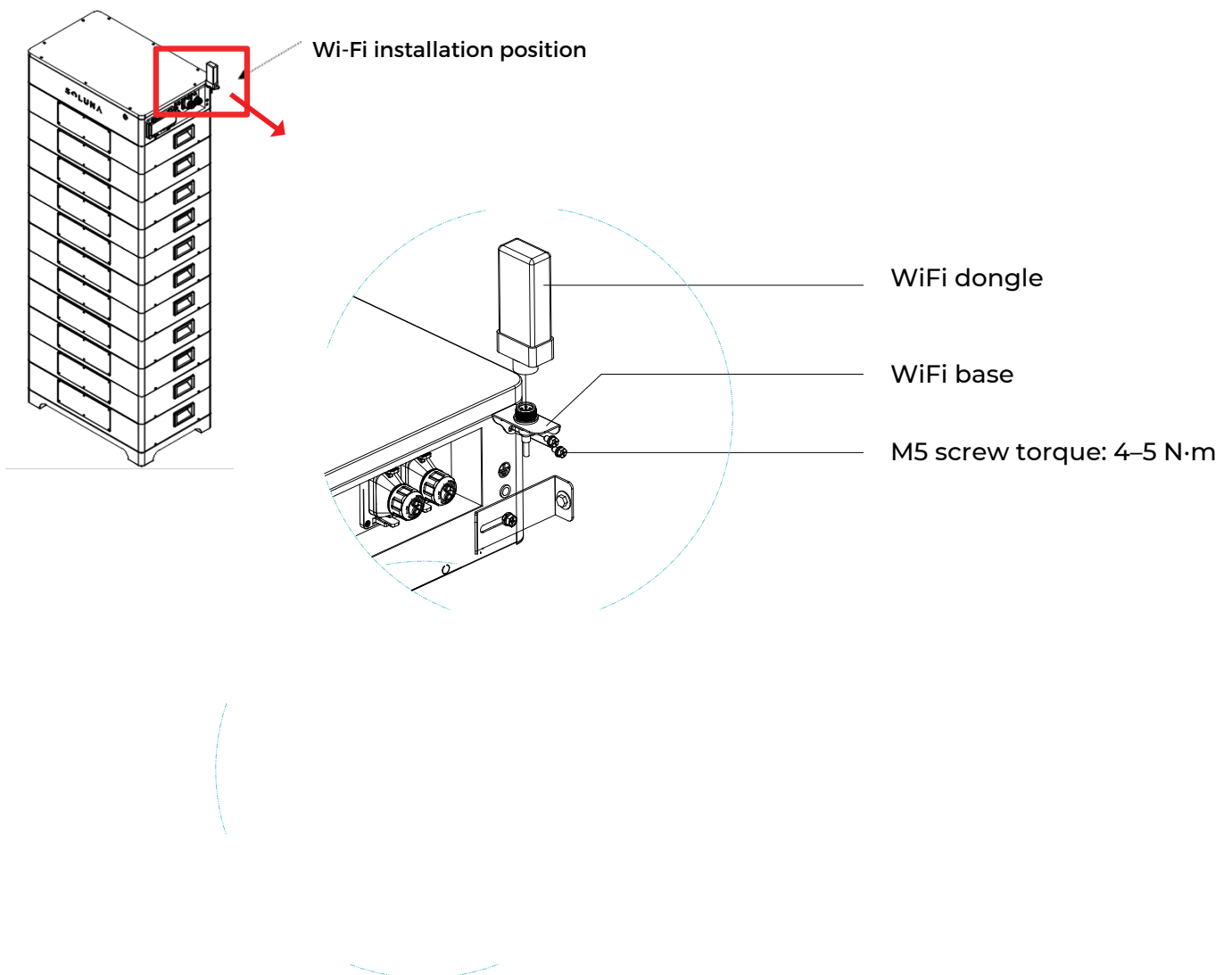

Remark:

When batteries are connected in parallel, the Wi-Fi dongle can be connected to either the first or the last battery.

8 Electrical connection

8.4 Electrical system connection diagram

Standalone

- Communication cable
- Battery positive pole
- Battery negative pole

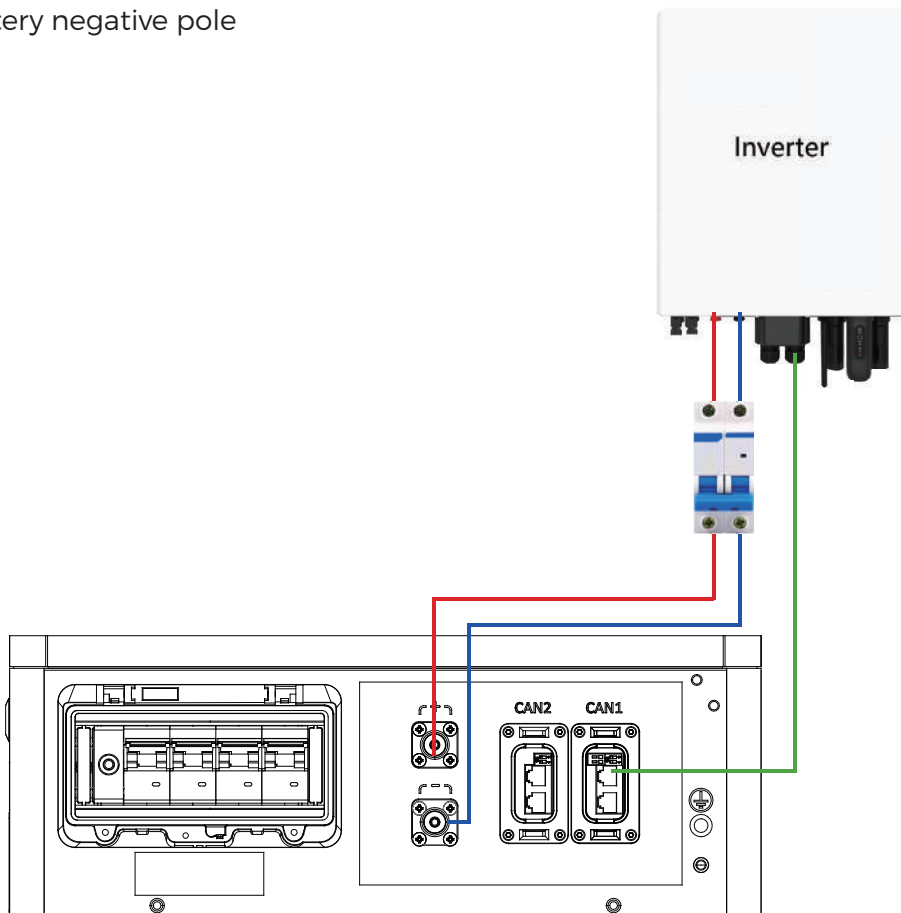

8 Electrical connection

8.4 Electrical system connection diagram

Multiple Clusters

- Communication cable
- Battery positive pole
- Battery negative pole

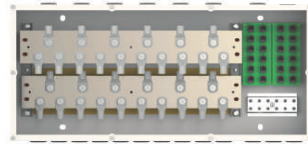

Busbar parameters: Recommended current 1200A, configurable according to system capacity.

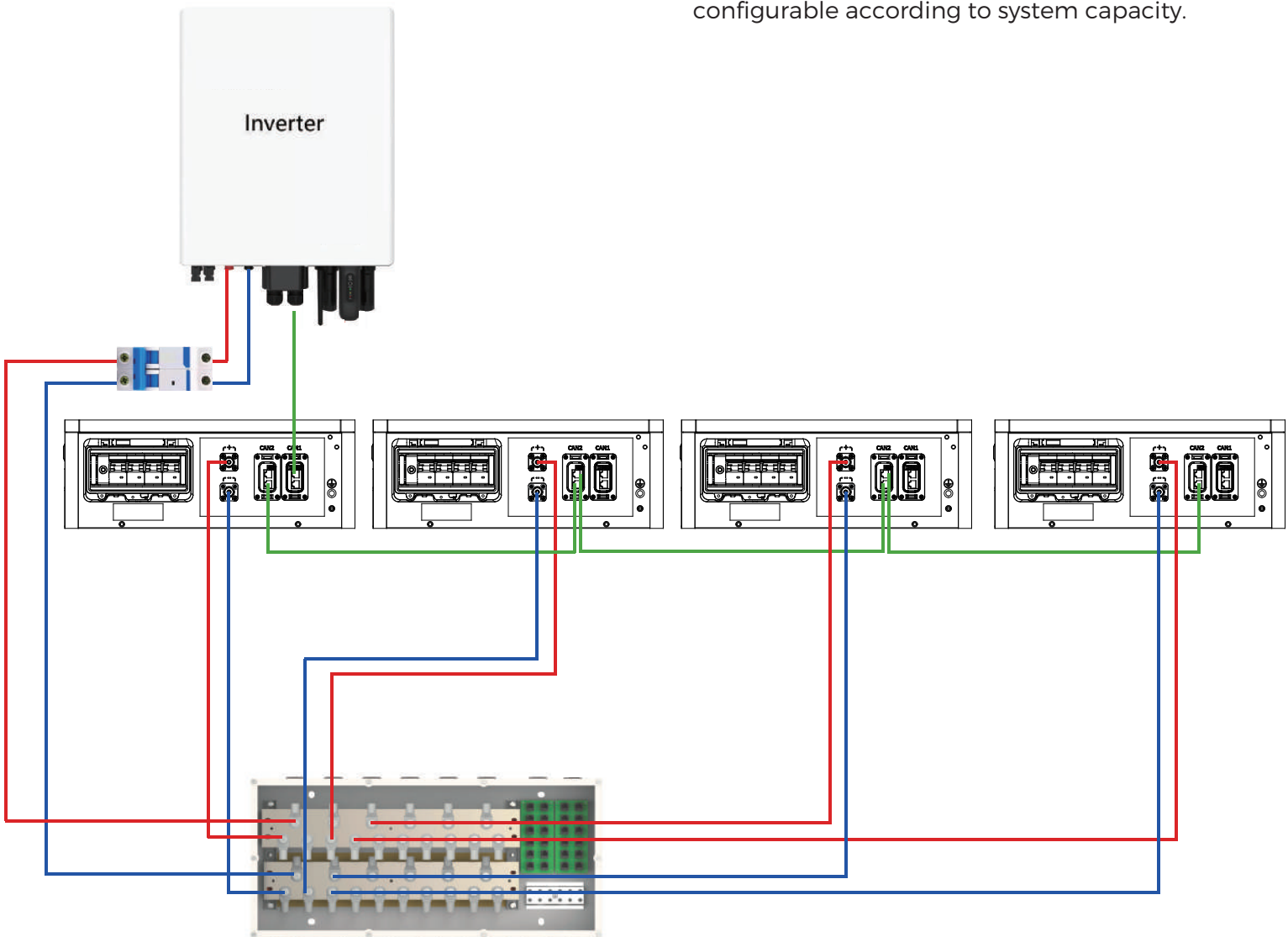

 2 units in parallel:
Turn the DIP switches of Can2 for both batteries to ON and the DIP switch of Can1 to position 1.2
ON/OFF

 3-10 units in parallel:
Turn the CAN2 DIP switches of the first and last batteries to ON.
Turn the CAN2 DIP switches of the middle batteries to positions 1.2
Keep the CAN1 DIP switches unchanged.
ON/OFF

NOTE: Parallel operation is permitted ****only when the batteries are of the same model and have the same number of modules****.

9 Operation instructions

9.1 Check before starting up

- Ensure the equipment is firmly installed, accessible for operation and maintenance, with adequate ventilation.
- Verify that ground, power, communication, and AC cables are properly and securely connected.
- Ensure cables are neatly bundled and undamaged.
- All switches should be OFF before power-up.

Warnings:

- Do not reverse polarity or short-circuit battery terminals.
- Do not misconnect BMS communication cables.
- Damage due to incorrect wiring is not covered under warranty..

9.2 Startup



Check Rotary switch:

Verify that the Rotary switch on the left side of the BMU matches the number of stacked modules (e.g., set to 5 for 5 modules).

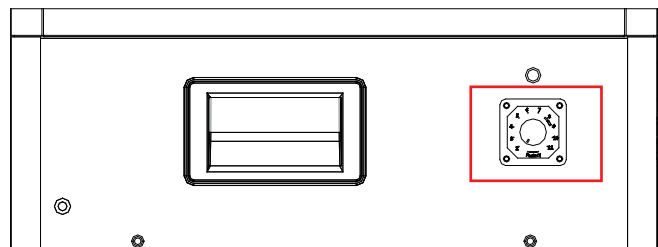







- **Step 1: Turn ON Breaker**
Wait about 1 minute for the battery status LED to illuminate.
- **Step 2: Power ON Inverter**
Enable inverter power (PV or grid), allowing the inverter to start.
- **Step 3: Select Battery Protocol**
Choose the correct battery communication protocol on the inverter to ensure proper communication.
- **Step 4: Test Charge/Discharge**
Verify that the battery can charge and discharge normally.

Notice:

- Soluna HV Ultra Series must communicate normally with the inverter to operate.
- In pure off-grid mode (no PV or grid), press and hold the black start button to activate the system.

10 status indicator light introduction

Please find the following table for details.

Number	Color	Description
1	 Red	1. Black start mode (activate by holding black start button for 10s) 2. BMS hardware fault
2	 Purple	Battery has lost communication with inverter for >5 minutes
3	 Yellow	Battery in protection mode (level 3 alarm: over/undervoltage, over/under temperature, etc.)
4	 White	Normal operation (master unit in parallel system)
5	 Green	Normal operation (slave unit in parallel system)
6	 Blue	BMS hardware anomaly

11 Maintenance and troubleshooting

11.1 Maintenance

- Recharge the battery system at least once every 6 months after leaving factory.
- Disconnect battery output if system will be unused for extended periods.
- Regularly inspect system status during operation (by qualified personnel).
- Clean system exterior and interior periodically (with power disconnected).
- During storage, check battery system regularly for abnormalities.

11.2 Troubleshooting

Faults	Cause	Maintenance method	Solution
LED light is purple	Compatible inverter firmware is not the latest reversion	Check the inverter APP or LCD/LED for firmware reversion	Update inverter's firmware
	Battery firmware is not the latest reversion	Check the Soluna smart energy cloud for firmware reversion	Update battery's firmware
	Installer didn't choose Soluna battery correctly on inverter APP or LCD/LED	Check if the selection of battery is correct or not	Reselect Soluna battery on inverter
	Communication cable is loose or not correct	Check the communication cable status	Replug or change the communication cable
	Inverter hardware fault	Change another inverter to try	Contact with inverter manufacture
	Battery hardware fault	If you checked all the items above and still can't target the reason, please contact with Soluna. Or change the battery	Contact with Soluna for further action

11 Maintenance and troubleshooting

Battery can't be charged or discharged	Inverter setting incorrect such as disable the charging or discharging, and time setting, etc.	Check the inverter setting	Change the inverter setting
	Inverter can't read Soluna battery type correctly.	Check the battery type of product and product name shown in inverter side.	Contact with Inverter manufacture or Soluna for further action.
	Inverter hardware fault.	Change another inverter to try.	Contact with Inverter manufacture.
	Battery hardware fault.	Please change another battery to try.	Contact with Soluna for further action.
LED light is off or yellow	Off-grid installation, battery can't be charged for over 2 weeks due to no production of PV system(raining season, snow season, or PV system fault).	Check the battery voltage.	Contact with Soluna for further action.
	Customer didn't turn off the battery for over 2 weeks in the scenario such as:A. Installation is not finished. B. System failure, not running.		
	The battery was stocked for over 2 years without charging.		
Battery firmware is not updated to latest	The battery firmware is continuously being optimized and updated	Check the Soluna smart energy cloud for battery firmware reversion.	Updating the battery firmware to the latest.
Master battery is white, but not all slaver battery are green	Battery communication cable is loose or not correct.	Check the communication cable status.	Replug or change the communication cable.
	Battery power cable is loose, or not correct connected.	Check the battery power cable.	Fasten the power cable.
	Communication terminal resistor is not dailed or not dailed correctly.	Check the parallel box for the resistor dailling.	Dail the terminal resistor according to manual or SOP.

11 Maintenance and troubleshooting

	Battery firmware is not the latest.	Check the Soluna smart energy cloud for battery firmware reversion.	Upgrade the firmware to the latest.
WIFI stick failed to configure the network	The Wifi network is not compatible	Check the ender user network type	Please choose only 2.4G wifi mode
	Connecting fail	APP will remind	Please read the SOP of wifi setting up
	System establish failed due to S/N invalid.	APP will remind	Contact with Soluna for further action
LED light is yellow	Battery reach to 3rd level alarm such as battery over voltage.	1.Check the inverter LCD/LED or APP for the battery alarm information. 2.Check the Soluna smart energy cloud for battery alarm information.	Battery will shut down, please contact with Soluna for further action.

Important:

Over-Discharge Recovery Timeline

- If temperature >25°C, recharge the over-discharged system within 7 days.
- If temperature <25°C, recharge within 15 days.
- If battery fails to start, contact Soluna after-sales service within 48 hours to avoid permanent damage.

12 Depth of Discharge(DOD) Setting for Inverter

To make sure the battery working smoothly, we recommend the DOD setting of inverter as follows.

On-Grid DOD: 80%

Off-Grid DOD: 70%

In energy storage systems, reducing the depth of discharge (DOD) of lithium batteries is aimed at improving system economics, extending battery life, enhancing safety, and optimizing performance. Below are the specific reasons:

1. Extending Battery Life

- The cycle life of lithium batteries is closely related to the depth of discharge. Deep discharge (e.g., 80%-100% DOD) accelerates battery aging, leading to faster capacity degradation.
- Reducing DOD (e.g., controlling it between 20%-80%) can significantly extend the battery's cycle life, thereby lowering long-term maintenance and replacement costs for the energy storage system.

2. Improving System Economics

- Batteries account for a significant portion of the cost in energy storage systems. Extending battery life means reducing the frequency of battery replacements and lowering the total lifecycle cost.
- Although reducing DOD decreases the available energy per cycle, the overall energy throughput (total charge-discharge capacity) may increase by extending battery life, thereby improving economic efficiency.

3. Enhancing Safety

- Deep discharge increases the risk of over-discharge, causing the battery voltage to drop too low, which may lead to irreversible chemical damage (e.g., dissolution of the copper current collector in the anode).
- Reducing DOD can prevent over-discharge, minimize safety risks such as thermal runaway, and ensure stable operation of the energy storage system.

13 Register on the Website after Installation

After completing the installation of the battery system and confirming that it is operating normally, please log in to the Soluna official website to register your product installation and usage details. This registration is required for the product warranty to take effect. Follow the on-screen instructions on the website to complete the registration process.

<https://soluna.co> → SUPPORT & SERVICE → Warranty registration

If you have any questions, feedback, or need assistance, please feel free to reach out to us. We are here to help!

Soluna (Shanghai) Co.,Ltd

Add: No.3492 Jinqian Road, Shanghai, China 201406

Tel: +86-21-57475835

Email: sales@solunabattery.com

Web: www.solunabattery.com

Social media: <https://www.linkedin.com/company/solunabattery>